



MARINE MODEL R30S-M

30" Electric Range w/Oven Base



Model R30S-ATAM

MARINE MODEL DESCRIPTION

Range shall be a LANG Manufacturing Marine Model R30S-____ [Specify one]:

- ATAM, with 4 ea. 8" diameter French Plates;
- ATBM, with 1 ea. 12" X 24" X 3/4" thick Hot Plate and 2 ea. 8" diameter French Plates
- ATCM, with 2 ea. 12" X 24" X 3/4" thick Hot Plates;
- ATDM, with 1 ea. 18" X 24" X 1/2" thick Griddle and 2 ea. 8" diameter French Plates;
- ATEM, with 1 ea. 18" X 24" X 1/2" thick Griddle and 1 ea. 12" X 24" X 3/4" thick Hot Plate or
- ATFM, with 30" X 24" X 1/2" thick Griddle

A 30" wide heavy duty electric heated unit with standard oven base and 14-kW total power input; hatchable two piece construction with all stainless steel exterior; fully insulated oven with aluminized steel interior, heavy duty drop-down door with latch and one oven rack standard; individual oven and cook-top component controls; Sea rails and stainless steel front grab bar.

STANDARD PRODUCT WARRANTY

- One year, parts & labor [Labor in U.S. only]

MARINE CONSTRUCTION FEATURES

- Two piece modular construction
- Heavy duty 430 Series stainless steel exterior with, No. 4 finish
- 12" high cooking compartment is aluminized steel
- 2" insulation on six sides of cooking compartment
- Incoloy sheathed tubular oven heating elements
- Heavy duty, spring-assisted, hinge-down oven door with latch
- One oven rack provided
- Sea rails and full width front mounted grab bar
- 2-3/4" wide full width front grease trough
- Grease drain in trough with full width & depth spillage drawers
- Griddle top configurations include one piece welded splash guard back & sides
- 4" adjustable legs w/ bolt-down flange standard

CONTROL PACKAGE

- Oven thermostat
- Top & bottom element 3-heat switches
- [-ATAM] Four individual 6-heat switches [ea. French Plate]
- [-ATBM] Two individual 6-heat switches [French Plates] & one 850 degree thermostat [Hot Top]
- [-ATCM] Two 850 degree thermostats [Hot Tops]
- [-ATDM] Two individual 6-heat switches [French Plates] & one thermostat [Griddle]
- [-ATEM] One 850 degree thermostat [Hot Top] & one thermostat [Griddle]
- [-ATFM] Two thermostats, one per 12" of Griddle plate

PERFORMANCE FEATURES

- Multi-function 30" wide unit fits into tight marine galleys
- Hatchable two-piece design allows movement through 26" x 66" watertight hatch
- Choice of six cook-top configurations, to include:
 - 4 ea. 8" diameter French Plates
 - 2 ea. 8" diameter French Plates & a 18" wide Griddle
 - 2 ea. 8" diameter French Plates & 1 ea. 12" wide Hot Top
 - 1 ea. 12" wide Hot Top & a 18" wide Griddle
 - 2 ea. 12" wide Hot Tops
 - 30" wide, 1/2" thick Griddle
- Full front grease trough, grease drain & spillage drawers
- Independent controls allows precise multi-function cookin



Sheet No. LMSP-R1 [rev. 07/15]

MARINE INSTALLATION REQUIREMENTS

- ☐ Ⓢ 208V or 240V, 1-Phase or 3-Phase power required; or 440V/480V, 3-Phase as option
- ☐ Consult marine codes for installation requirements

MARINE OPTIONS & ACCESSORIES

- 440V/480V, 3-phase model
- Stainless steel oven interior
- Set of 6" Legs [Required for NSF Listing]
- Add curb mounting flange
- Extra wire pan rack [One provided as std.]

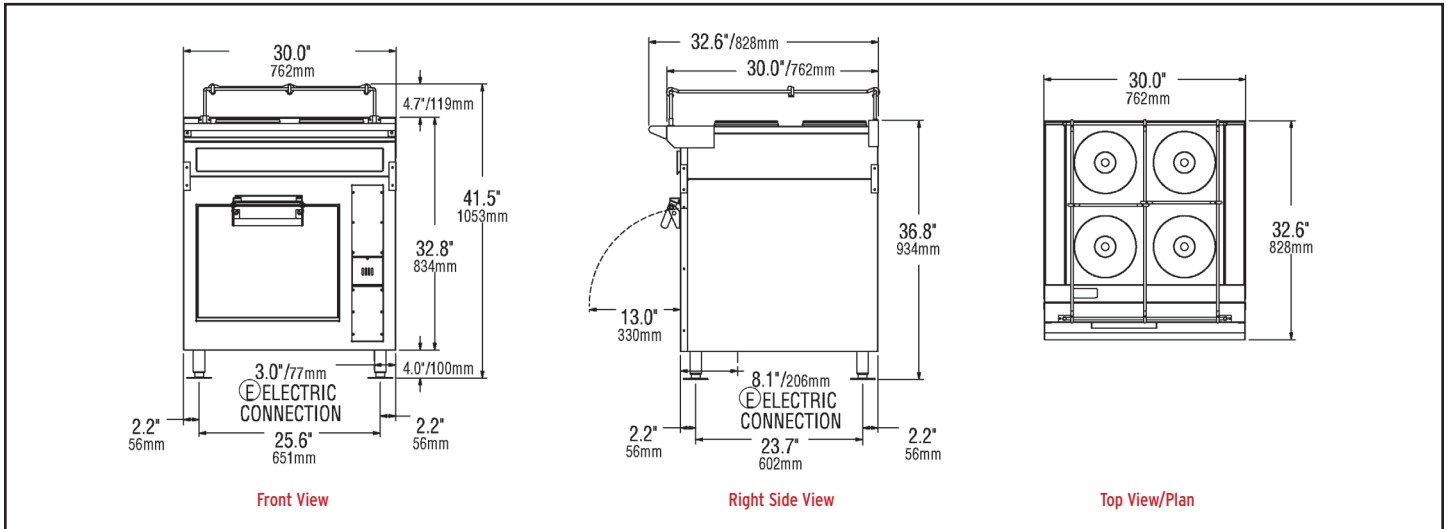

Model [R30S]	ATAM	ATDM	ATBM	ATEM	ATCM	ATFM
Oven Base	Standard	Standard	Standard	Standard	Standard	Standard
Griddle	-	18"	-	18"	-	30"
French Plates	4 each	2 each	2 each	-	-	-
Hot Plates	-	-	1 each	1 each	2 each	-
Pictogram						

Model No.	External Dimensions			Surface Clearance	Weight lbs [kg]		Freight Class	Volts AC [Hz]	Watts [kW]	3-Phase AMPS	1-Phase AMPS
	Width	Height	Depth		Actual*	Ship*					
R30S	30.0" 762mm	41.7" 1053mm	32.6" 828mm	Sides: 4" Back: 4"	360 [164]	410 [186]	85	208 - 50/60	14.0	41.7	67.8
								240 - 50/60	14.0	36.1	58.3
								440 - 50/60	11.8	16.6	n/a
								480 - 50/60	14.0	18.1	n/a

*Depending on configuration

CAD SYMBOLS & PRICING

Sheet No. LMSP-R1 [rev. 07/15]



Due to continuous improvements, specifications subject to change without notice

