

UPRIGHT REACH-IN GLASS DOOR REFRIGERATORS

Top Mounted Condensing Unit

ES - Series • ESGR1 • ESGRH2 • ESGR2 • ESGRH4 • ESGRW2 • ESGR3A



▲ ESGR1



▲ ESGRH2



▲ ESGR2



▲ ESGRH4



▲ ESGRW2



▲ ESGR3A

Cabinet Construction

- Heavy duty stainless steel interior / exterior with rounded corners for a hazard-free workspace.
- Galvanized steel top, bottom and rear.
- 2.5" thick high density polyurethane insulation.
- Four 5" swivel casters with locks on front set. Leg stabilizers standard for models ESGR1, ESGRH2, and ESGR3A.

Refrigeration System

- Top mounted, self-contained and fully detachable Blizzard R290 condensing unit uses environmentally friendly, EPA-compliant R290 refrigerant with zero (0) Ozone Depletion Potential (ODP) and three (3) Global Warming Potential (GWP). Blizzard R290 is easily replaceable and requires no on-site brazing.
- Electronically commutated (ECM) fan motors achieve rapid cooling with less energy consumption.
- Full-length air duct system and airflow guard ensure optimal circulation of cold air.
- Time-initiated and temperature-terminated auto defrost cycle for seamless operation.
- Large capacity, corrosion-resistant condenser and evaporator coils.
- Self-maintaining, energy-efficient condensate drain pan requires no external drains or electric heaters.
- High performance, auto-reverse condenser fan motor supports compressor ventilation and condenser coil cleaning. Refer to owner's manual for full maintenance instructions.
- Pressure relief devices allow smooth access to cabinet interior when re-opening doors.
- Pre-wired and ready to plug, 115V/60Hz/1Ph, NEMA 5-15P.

Lighting

- Shielded LED bar lighting with on/off switch provides bright, high color illumination at lower heat output.

Doors

- Low emissivity double glass panes reflect UV rays for efficient cooling.
- Matte finish aluminum door frames.
- Frame heaters prevent exterior moisture build up.
- Self-closing with adjustable torsion system for a positive seal.
- Snap-in magnetic door gasket make cleaning and replacement an easy process.
- High strength, die-cast door handles.
- Pre-installed door locks keep your items safe from theft (does not apply to models ESGRH2 and ESGRH4).
- Field reversible (does not apply to model ESGRH2).

Shelving

- Four epoxy coated, steel wire shelves per section.
- Height adjustable stainless steel clips.

Temperature Control

- Multi-function digital controller with easy to read LED display.
- Factory preset temperature, 35°F. Temperature setting range from 33°F to 54°F.
- Audible overheat protection alarm for compressor and condenser coil.

Options

- Additional shelving.
- 3" swivel casters with locks.
- 3.5" – 6" height-adjustable and interchangeable legs.



Dimensions

ABS Legs



Two additional front adjustable stainless steel clad ABS legs for model ESGR1 to provide extra stability when opening and closing door, and one additional leg for model ESGR3A for weight support.



Equipped with 9 ft long NEMA 5-15P plug.

Side View

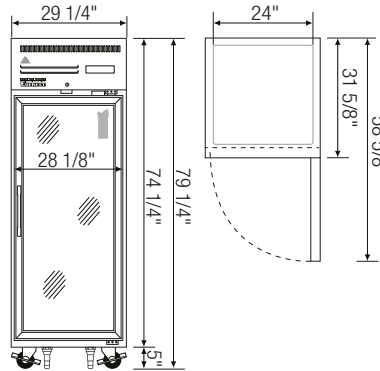
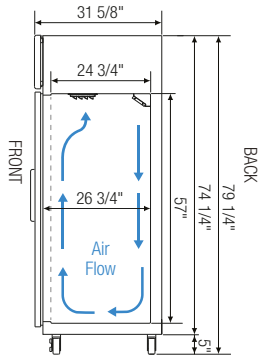

▲ ESGR1

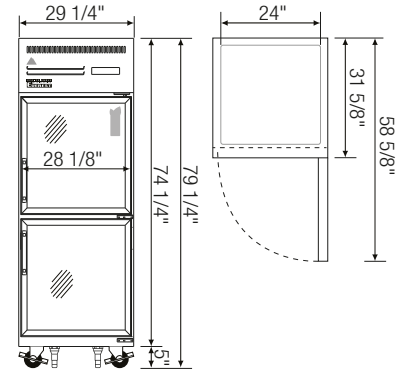

▲ ESGRH2

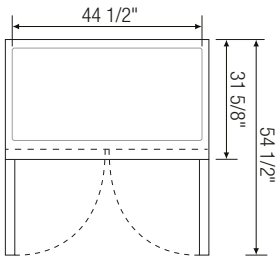

▲ ESGR2

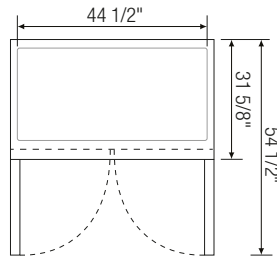

▲ ESGRH4

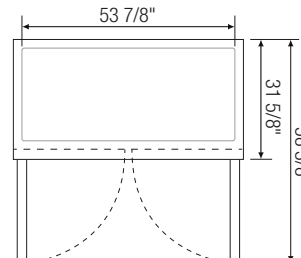

▲ ESGWR2

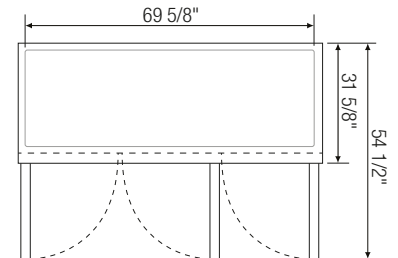

▲ ESGR3A

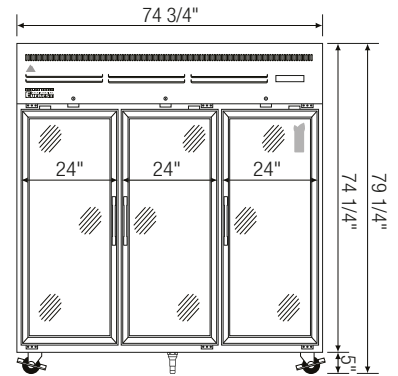
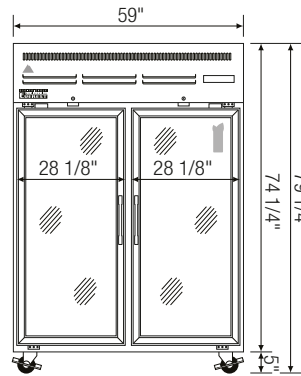
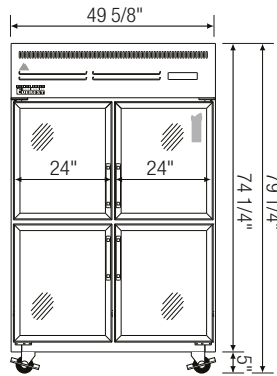
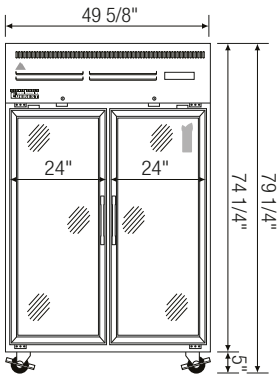

Model	Ref/ Frz/ Dual	# of Doors	Capacity (Cu. Ft.)	HP	BTU/HR [†]	Refrigerant	# of Shelves	Power (V-Hz-Ph)	Amps	Crated Weight (LBS)	Exterior Dimensions (Inches)		
											L	D ^a	H [*]
ESGR1	Ref	1	23	1/4+	1,926	R290	4	115-60-1	3.7	329	29 1/4	31 5/8	74 1/4
ESGRH2	Ref	2 (H)	23	1/4+	1,926	R290	4	115-60-1	3.7	329	29 1/4	31 5/8	74 1/4
ESGR2	Ref	2	48	1/3	2,311	R290	8	115-60-1	3	467	49 5/8	31 5/8	74 1/4
ESGRH4	Ref	4 (H)	48	1/3	2,311	R290	8	115-60-1	3	467	49 5/8	31 5/8	74 1/4
ESGWR2	Ref	2	55	1/2	1,670	R290	8	115-60-1	5.5	540	59	31 5/8	74 1/4
ESGR3A	Ref	3	71	3/4	4,445	R290	12	115-60-1	7.8	663	74 3/4	31 5/8	74 1/4

* : Height does not include 5" for casters.

(H) = Half Door | Ref = Refrigerator

† : Based on evaporating temperature of 23°F (-5°C) & condensing temperature of 131°F (55°C).

a : Exterior depth dimension does not include 1-1/2" for door handles.

Specifications subject to change without notice.

Product dimensions are for general purposes and not absolute value. Product capacity () is calculated based on standard industry figures. Slight variations may exist. If dimensions and capacity are critical, please contact Everest Refrigeration.



Please visit our website for updated Energy Efficiency information.