

SIDE MOUNT GLASS DOOR UNDERCOUNTER REFRIGERATORS

Side Mounted Condensing Unit



EVEREST
REFRIGERATION

www.EVERESTref.com

ETG – Series

• ETGSR2 • ETGR2 • ETGWR2



ETGSR2



ETGR2



ETGWR2

Cabinet Construction

Heavy duty stainless steel interior and exterior, with galvanized steel finished bottom and back wall of exterior. High quality 16 gauge stainless steel worktop, ABS evaporator drain cover. 2.5" thick high density foamed-in-place polyurethane insulation. Four 4" diameter casters (front casters with brakes).

Refrigeration System

- Side mounted condensing unit for extra interior space use compared to back mounted units
- Oversized condenser and evaporator coils quickly achieve and maintain desired temperature
- Forced-air cooling with oversized evaporator fan motors providing balanced airflow throughout cabinet to ensure faster temperature drop
- Removable side panel and slide-out condensing unit for convenient repair and maintenance
- Removable condenser coil air filter for easy cleaning
- Environmentally friendly CFC free R-134A refrigerant
- Air defrost, temperature initiated and terminated
- Copper tube and aluminum fin evaporator with anti-corrosive coating
- Energy efficient condensate drain pan assembly heated by high side copper tube
- Pressure relief port for rapid cabinet re-entry
- Pre-wired and ready to plug, 115V/60Hz/1Ph, NEMA 5-15P

Doors

- Grey PVC door frames standard from June, 2013
- Low emissivity double pane glass system reflects UV rays and improves insulation for maximized energy efficiency
- Removable doors and stainless steel door tracks for easy cleaning

Lighting

- Shielded vertical LED interior lighting with on/off switch for energy saving, less heat generation and enhanced illumination

Shelving

- Two epoxy coated wire shelves per section
- Stainless steel pilasters and shelf clips

Temperature Control

- Factory preset temperature, 35°F
- Temperature setting range from 33°F to 54°F
- Easy to read digital temperature display
- Easy to program push button temperature control
- Microchip digital control and monitoring system with a variety of functions to monitor and maintain optimum temperature

Option

- 4" high stainless steel backsplash for worktop use

• Project / Customer _____

• Item No. _____

• Model No. _____

Warranty

 **5 Year — Compressor Warranty**
3 Year — Parts & Labor Warranty
Applicable to units purchased after July 1, 2014.

Contact

 201 W. Artesia Blvd, Compton, CA 90220
T. (310) 323-6586, (800) 444-6285
F. (310) 323-7524, (310) 761-1127

SIDE MOUNT GLASS DOOR UNDERCOUNTER REFRIGERATORS (SIDE MOUNT)

SIDE MOUNT GLASS DOOR UNDERCOUNTER REFRIGERATORS

Side Mounted Condensing Unit



ETG – Series

• ETGSR2 • ETGR2 • ETGWR2

Dimensions

SIDE VIEW

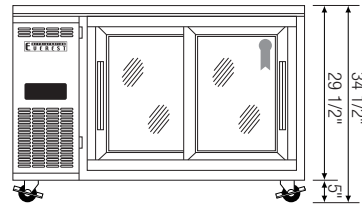
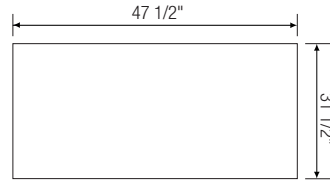
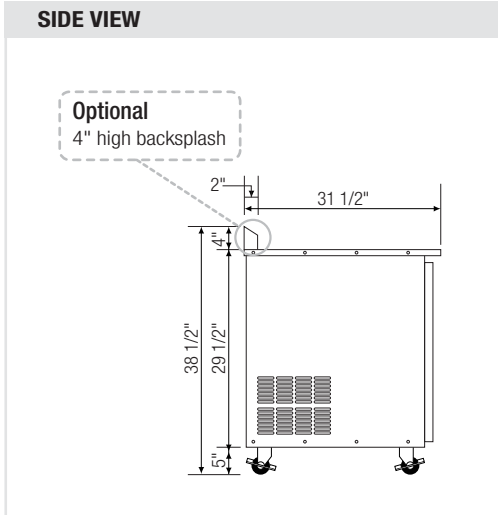

▲ ETGSR2

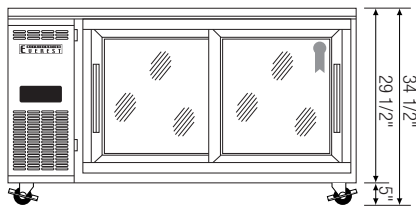
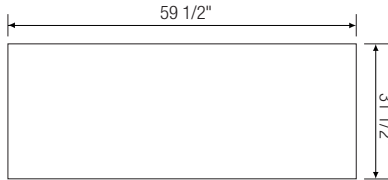

▲ ETGR2

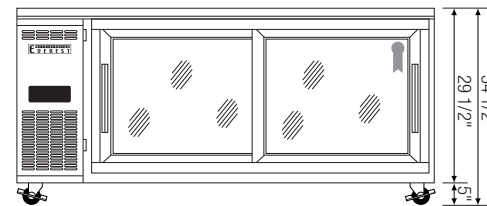
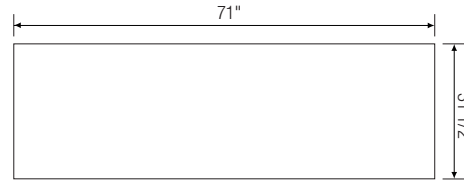

▲ ETGWR2

Model	Ref/ Frz/ Dual	# of Doors	Capacity (Cu.Ft.)	HP	Refrigerant	# of Shelves	Power (V-Hz-Ph)	Amps	Crated Weight (LBS)	Exterior Dimensions (Inches)			* Height does not include 5" for casters Ref = Refrigerator Frz = Freezer Dual = Ref & Frz Combo
										L	D	H *	
ETGSR2	Ref	2 (Sliding)	13	1/4	R-134A	4	115-60-1	4.08	282	47 1/2	31 1/2	29 1/2	
ETGR2	Ref	2 (Sliding)	18	1/4	R-134A	4	115-60-1	4.13	318	59 1/2	31 1/2	29 1/2	
ETGWR2	Ref	2 (Sliding)	23	1/3	R-134A	4	115-60-1	4.89	355	71	31 1/2	29 1/2	

Disclaimer: Product dimensions are for general purposes and not absolute value. Slight variations may exist. If dimensions are critical, please contact Everest.