

# SIDE MOUNT UNDERCOUNTER FREEZERS

Side Mounted Condensing Unit



**EVEREST**  
REFRIGERATION

www.EVERESTref.com

SIDE MOUNT UNDERCOUNTER FREEZERS (SIDE MOUNT)

## ET – Series

• ETF1 • ETF2 • ETWF2 • ETF3



ETF1



ETF2



ETWF2



ETF3

### Cabinet Construction

Heavy duty stainless steel interior and exterior, with galvanized steel finished bottom and back wall of exterior. High quality 16 gauge stainless steel worktop, ABS evaporator drain cover. 2.5" thick high density foamed-in-place polyurethane insulation. Four 4" diameter casters (front casters with brakes). Door heater installed around inside cabinet frame to prevent moisture build-up.

### Refrigeration System

- Side mounted condensing unit for extra interior space compared to back mounted units
- Oversized condenser and evaporator coils quickly achieve and maintain desired temperature
- Forced-air cooling with oversized evaporator fan motors providing balanced airflow throughout cabinet to ensure faster temperature drop
- Removable side panel and slide-out condensing unit for convenient repair and maintenance
- Removable condenser coil air filter for easy cleaning
- Environmentally friendly CFC free R-134A and R-404A refrigerant
- Adjustable, time initiated defrost cycle of 3 to 12 hours with 350 watt defrost heater, both time and temperature terminated for fail-safe operation
- Copper tube and aluminum fin evaporator with anti-corrosive coating
- Energy efficient condensate drain pan assembly heated by high side copper tube
- Pressure relief port for rapid cabinet re-entry
- Pre-wired and ready to plug, 115V/60Hz/1Ph, NEMA 5-15P

### Doors

- Heavy duty stainless steel interior and exterior
- 2.5" thick foamed-in-place polyurethane insulation
- Rounded corners for a sleek and modern appearance
- Heavy duty adjustable torsion spring self-closing door system
- One piece snap-in magnetic door gaskets for easy replacement
- Heavy duty recessed door handles for a flat surface
- All 2015 and newer models come standard with door locks

### Lighting

- Shielded incandescent interior lighting

### Shelving

- Two epoxy coated wire shelves per section
- Stainless steel pilasters and shelf clips

### Temperature Control

- Factory preset temperature, -4°F
- Temperature setting range from -10°F to 54°F
- Easy to read digital temperature display
- Easy to program push button temperature control
- Microchip digital control and monitoring system with a variety of functions to monitor and maintain optimum temperature

### Option

- 4" high stainless steel backsplash for worktop use

• Project / Customer \_\_\_\_\_

• Item No. \_\_\_\_\_

• Model No. \_\_\_\_\_



### Warranty

**5 Year — Compressor Warranty**  
**3 Year — Parts & Labor Warranty**  
Applicable to units purchased after July 1, 2014.

### Contact

201 W. Artesia Blvd, Compton, CA 90220  
T. (310) 323-6586, (800) 444-6285  
F. (310) 323-7524, (310) 761-1127

# SIDE MOUNT UNDERCOUNTER FREEZERS

Side Mounted Condensing Unit



**EVEREST**  
REFRIGERATION

www.EVERESTref.com

## ET – Series

• ETF1 • ETF2 • ETWF2 • ETF3

### Dimensions

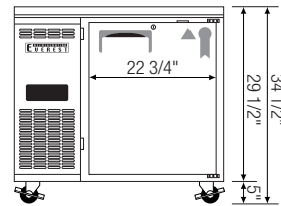
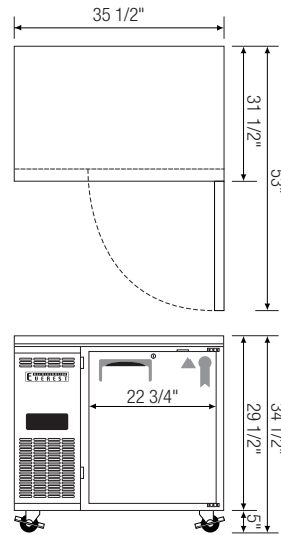
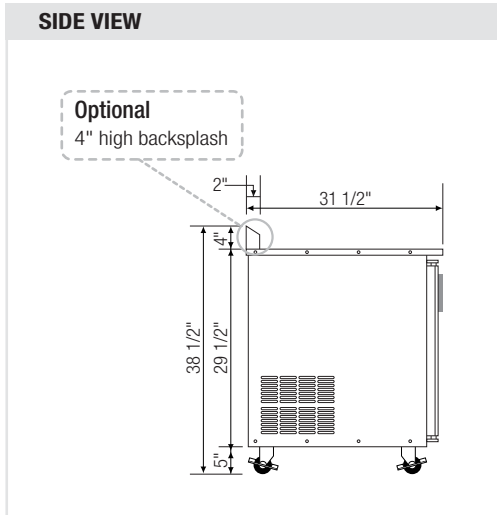

▲ ETF1

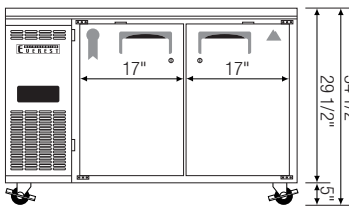
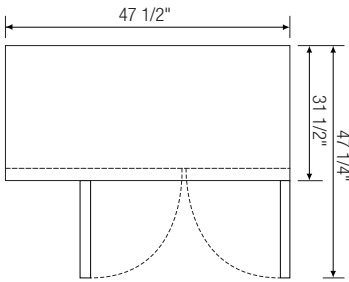

▲ ETF2

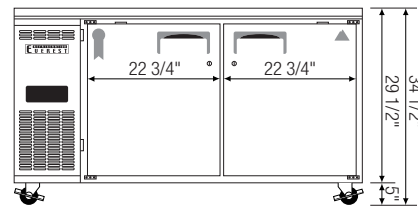
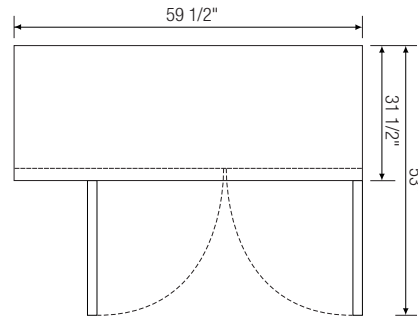

▲ ETWF2

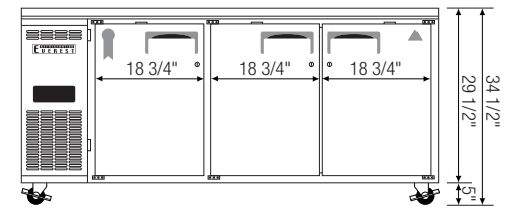
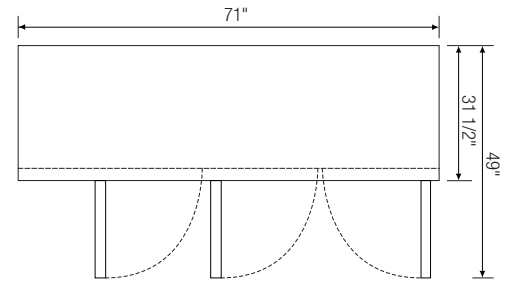

▲ ETF3

Model	Ref/ Frz/ Dual	# of Doors	Capacity (Cu.Ft.)	HP	Refrigerant	# of Shelves	Power (V-Hz-Ph)	Amps	Crated Weight (LBS)	Exterior Dimensions (Inches)			* Height does not include 5" for casters  Ref = Refrigerator Frz = Freezer Dual = Ref & Frz Combo
										L	D	H *	
ETF1	Frz	1	9	1/3	R-134A	2	115-60-1	4.41	231	35 1/2	31 1/2	29 1/2	
ETF2	Frz	2	13	1/2+	R-404A	4	115-60-1	7.50	273	47 1/2	31 1/2	29 1/2	
ETWF2	Frz	2	18	1/2+	R-404A	4	115-60-1	7.50	300	59 1/2	31 1/2	29 1/2	
ETF3	Frz	3	22	1/2+	R-404A	6	115-60-1	7.67	333	71	31 1/2	29 1/2	

Disclaimer: Product dimensions are for general purposes and not absolute value. Slight variations may exist. If dimensions are critical, please contact Everest.