

SIDE MOUNT SANDWICH PREP. TABLES

Side Mounted Condensing Unit



EVEREST
REFRIGERATION
www.EVERESTref.com

EP – Series

• EPR1 • EPR2 • EPWR2 • EPR3



EPR1



EPR2



EPWR2



EPR3

Cabinet Construction

Heavy duty stainless steel interior and exterior, galvanized steel finished bottom and back wall of exterior. High quality 16 gauge stainless steel worktop, top lid and hood. 2.5" thick high density foamed-in-place polyurethane insulation. Four 4" diameter casters (front casters with brakes). Door heater installed around inside cabinet frame to prevent moisture build-up.

Refrigeration System

- Side mounted condensing unit for extra interior space compared to back mounted units
- Oversized condenser and evaporator coils quickly achieve and maintain desired temperature
- Forced-air cooling with oversized evaporator fan motors providing balanced airflow throughout cabinet to ensure faster temperature drop
- Removable side panel and slide-out condensing unit for convenient repair and maintenance
- Removable condenser coil air filter for easy cleaning
- Environmentally friendly CFC free R-134A refrigerant
- Air defrost, temperature initiated and terminated
- Copper tube and aluminum fin evaporator with anti-corrosive coating
- Energy efficient condensate drain pan assembly heated by high side copper tube
- Pressure relief port for rapid cabinet re-entry
- Pre-wired and ready to plug, 115V/60Hz/1Ph, NEMA 5-15P

Doors

- Heavy duty stainless steel interior and exterior
- 2.5" thick high density foamed-in-place polyurethane insulation
- Rounded corners for a sleek and modern appearance
- Heavy duty adjustable torsion spring self-closing door system
- One piece snap-in magnetic door gasket for easy replacement
- Heavy duty recessed door handles for a flat surface

Lighting

- Shielded incandescent interior lighting

Preparation Area

- 1/2" thick foam insulated lids to prevent moisture build-up and heat exchange
- Removable and adjustable sanitary 12 1/4" deep cutting board
- Sanitary polycarbonate pans

Shelving

- Two epoxy coated wire shelves per section
- Stainless steel pilasters and shelf clips

Temperature Control

- Factory preset temperature, 35°F
- Temperature setting range from 33°F to 54°F
- Easy to set analog thermostat

SIDE MOUNT SANDWICH PREP. TABLES (SIDE MOUNT)

• Project / Customer _____

• Item No. _____

• Model No. _____



Warranty

5 Year — Compressor Warranty
3 Year — Parts & Labor Warranty
Applicable to units purchased after July 1, 2014.

Contact

201 W. Artesia Blvd, Compton, CA 90220
T. (310) 323-6586, (800) 444-6285
F. (310) 323-7524, (310) 761-1127

SIDE MOUNT SANDWICH PREP. TABLES

Side Mounted Condensing Unit



EP – Series

• EPR1 • EPR2 • EPWR2 • EPR3

Dimensions

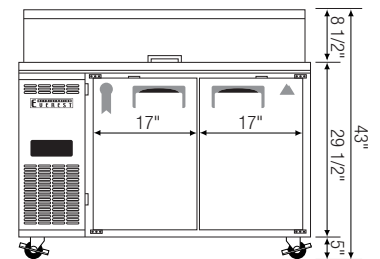
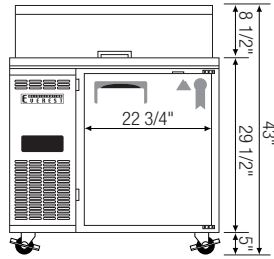
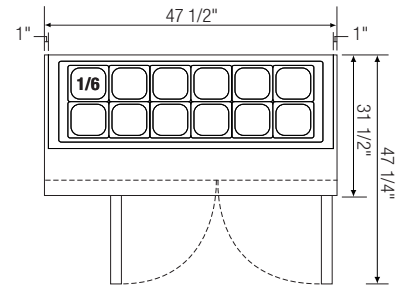
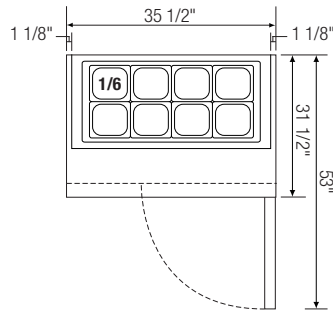
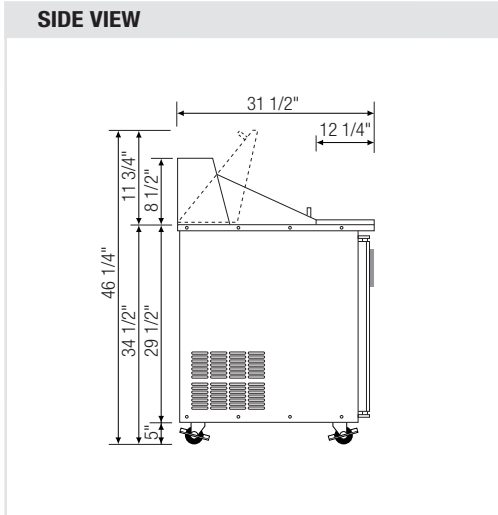

▲ EPR1

▲ EPR2

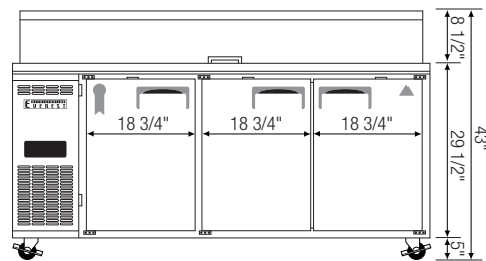
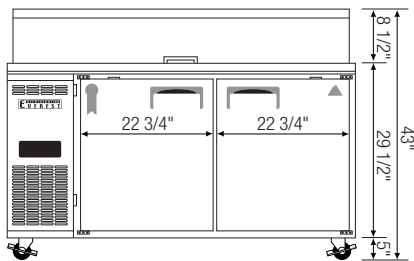
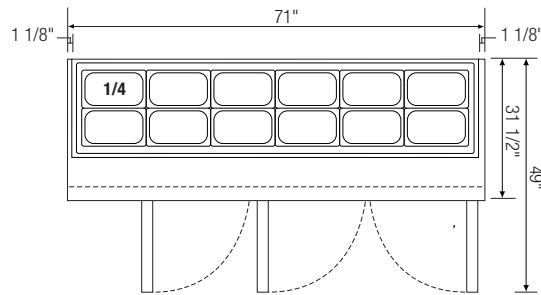
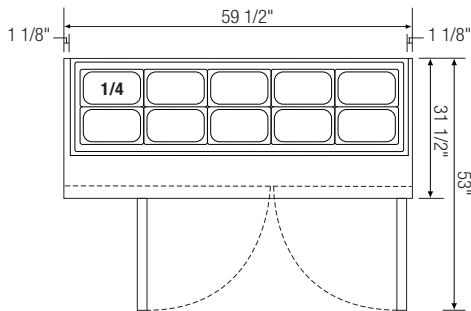

▲ EPWR2

▲ EPR3

| Model | Ref/ Frz/ Dual | # of Doors | Capacity (Cu.Ft.) | HP | Refrigerant | # of Shelves | # of Pans | Power (V-Hz-Ph) | Amps | Crated Weight (LBS) | Exterior Dimensions (Inches) | | | * Height does not include 5" for casters Ref = Refrigerator Frz = Freezer Dual = Ref & Frz Combo |
|-------|----------------------|---------------|----------------------|-----|-------------|-----------------|--------------|--------------------|------|---------------------------|---------------------------------|--------|----|--|
| | | | | | | | | | | | L | D | H* | |
| EPR1 | Ref | 1 | 9 | 1/4 | R-134A | 2 | 1/6 X 8 | 115-60-1 | 3.97 | 267 | 35 1/2 | 31 1/2 | 38 | |
| EPR2 | Ref | 2 | 13 | 1/4 | R-134A | 4 | 1/6 X 12 | 115-60-1 | 4.01 | 340 | 47 1/2 | 31 1/2 | 38 | |
| EPWR2 | Ref | 2 | 15 | 1/4 | R-134A | 4 | 1/4 X 10 | 115-60-1 | 4.01 | 363 | 59 1/2 | 31 1/2 | 38 | |
| EPR3 | Ref | 3 | 23 | 1/3 | R-134A | 6 | 1/4 X 12 | 115-60-1 | 5.20 | 434 | 71 | 31 1/2 | 38 | |

Disclaimer: Product dimensions are for general purposes and not absolute value. Slight variations may exist. If dimensions are critical, please contact Everest.