



Culinary Precision™

### Drop in Gas Cooktops – Install Quick Specs CTSG305DS and CTSG305DSL

#### Installation Type

Drop into countertop opening

Gas supply & electrical cord are located off the right rear of the cooktop.

#### Overall & Cutout Dimension(s)

|            |         |         |    |
|------------|---------|---------|----|
| CTSG305DS  | A       | B       | C  |
| CTSG305DSL |         |         |    |
| Overall    | 30"     | 20 1/8" | 3" |
|            | D       | E       |    |
| Cutout     | 29 3/8" | 19 1/2" |    |

#### Cooktop Carton Weight:

CTSG305DS = 68 lbs.

CTSG305DSL = 68 lbs.

#### Standard Features

- 304 Series, 18 gauge stainless steel maintop and frame.
- Five burner models (CTSG305DS)- *natural gas* or (CTSG305DSL) *liquid propane*.
- Features two dual port Culinary™ burners and three single port burners.
- All burners feature brass orifices for more precise flame control.
- FlameGuard™ single point electronic ignition and re-ignition system.
- Low grate profile of only 1" above countertop.
- Shallow rough-in box depth for extra cabinet storage.
- Die cast, brushed stainless knobs with protective clear coat.

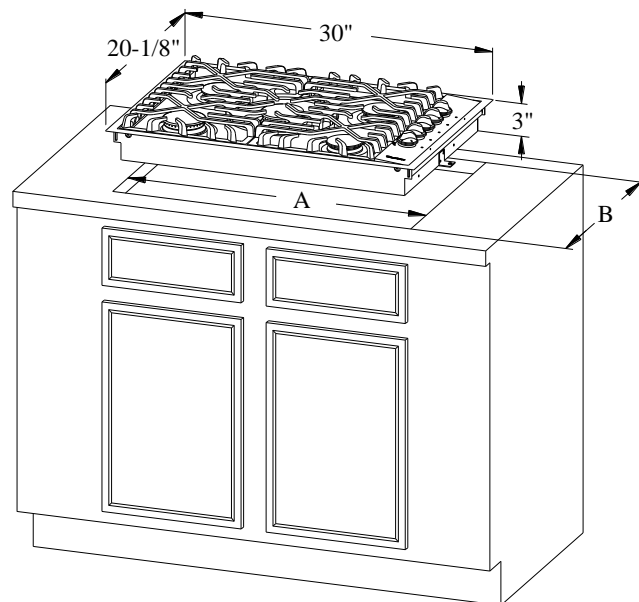

#### Finishes

- Stainless Steel (S)

#### Gas Supply Requirements\*

NG Standard: 1/2" regulator (6 to 14 inches water column/Manifold at 4-inches)

LP Standard: 1/2" regulator (11 to 14 inches water column/Manifold at 10-inches)

\*Regulator ships in box with cooktop. LP gas tank must have its own pressure regulator in addition to the one provided with the cooktop.

#### Maximum Power Supply Required

15 Amps @ 120 V AC, 60 Hz, single phase  
Cooktop comes with a 4' long, grounded cord.  
A three-prong grounded receptacle is required.

Copyright © 2012 Wind Crest™ by CNP Industries, Inc.

Install Quick Specs are for planning purposes only. Please refer to the detailed installation instructions, prior to making any cutouts.

