













MOFFAT® E311MS

Half Size Electric Convection Oven

-  Commercial construction
-  Stainless steel outer
-  Stainless steel door with full viewing window
-  Stay cool heavy duty stainless steel door handle
-  4 half pan capacity
-  60 minute bake timer
-  3 hour roast timer
-  Cook n hold system
-  Insulated porcelain inner
-  Internal lighting
-  Water injected steam (hook-up optional)
-  Broiling element



E311MS



Order Toll Free 1800 551 8795

E311MS

Unit shall be a Moffat electrically heated Turbofan convection oven E.T.L listed (UL Std 197) and NSF listed (NSF-4). The oven shall have a one piece vitreous porcelain enamel oven liner, stainless steel top and sides with single stainless steel door and full viewing window. Oven liner shall be insulated on all sides and have capacity for four half size sheet pans. A single speed fan shall evenly circulate air internally.

The oven shall be controlled by a mechanical thermostat with a range from 150°F to 525°F, have a broil switch built into the thermostat, a 60 minute bake timer, 3 hour cook n hold timer, push button water injection and oven light switch. Oven shall be able to be bench mounted on 4" legs or on Moffat's A25 stand. Oven shall be fitted with a NEMA 6-15P cordset.

MOFFAT® E311MS

Half Size Electric Convection Oven

MOFFAT®

www.moffat.com

CONSTRUCTION

Stainless steel top and sides
 Porcelain oven interior
 Toughened twin pane door glass
 Strong and stylish door handle
 4 half pan capacity (wire racks included)
 Fully insulated
 Stainless steel control panel with overlay
 Fully enclosed motor at rear

CONTROLS

On/off switch
 Mechanical thermostat, variable between 150°F to 525°F
 3 hour roast timer
 Cook n hold factory preset at 158°F (range 140°F to 194°F)
 Water injection steam (momentary switch)
 Low velocity fan system
 Broil position for cheesemelting/toasting
 Oven light

CLEANING AND SERVICING

Fully removable racks and fan baffle
 Fully removable bottom element guard
 Easy clean surfaces
 Access to all controls from front panel
 No tools required to replace lamps
 Removable gaskets - no tools required

OPTIONS

Stand with casters
 Half size sheet pans

SPECIFICATIONS

Electrical requirements
 208V, 60Hz, 1P+N+E, 2.9kW, 14.0A
 220-240V, 60Hz, 1P+N+E, 3.1kW, 13.0A
 NEMA 6-15P cordset fitted

Water
 $\frac{3}{4}$ " thread
 80psi max inlet pressure
 20psi min inlet pressure



External Dimensions
 Width 31 $\frac{3}{8}$ " (796mm)
 Height 22 $\frac{7}{8}$ " (567mm)
 Depth 23 $\frac{5}{8}$ " (600mm)

Internal Dimensions
 Width 21 $\frac{1}{2}$ " (544mm)
 Height 16 $\frac{1}{2}$ " (418mm)
 Depth 15 $\frac{1}{8}$ " (385mm)

Oven Rack Dimensions
 Width 20 $\frac{7}{8}$ " (530mm)
 Depth 14 $\frac{1}{2}$ " (370mm)

Nett Weight
 189lbs (86kg)

Packing Data
 227lbs (103kg)
 14.5ft³ (0.41m³)
 Width 32 $\frac{7}{8}$ " (835mm)
 Height 28 $\frac{1}{2}$ " (720mm)
 Depth 27 $\frac{1}{4}$ " (690mm)

Clearances
 Left side 1" (25mm)
 Right side 1" (25mm)
 Rear 1" (25mm)
 Top 8" (200mm)

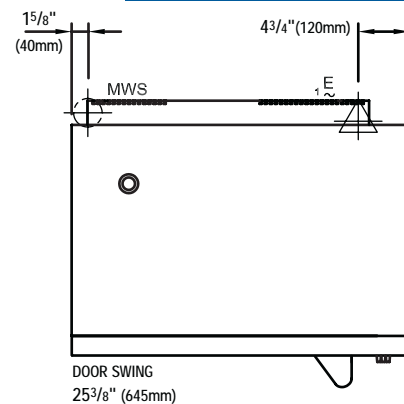
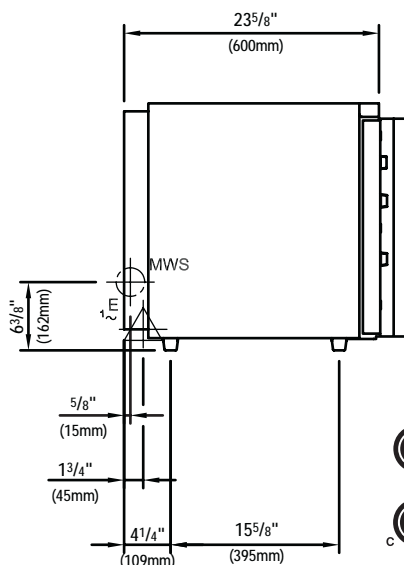
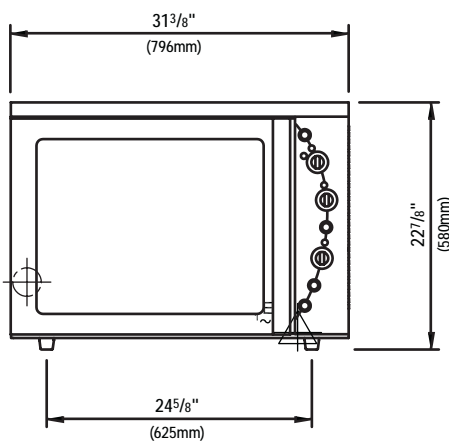

DOOR SWING
 25 $\frac{3}{8}$ " (645mm)



ISO 9001
 All Turbofan products are designed and manufactured by Moffat Ltd using the internationally recognised ISO 9001 quality management system, covering design, manufacture and final inspection, ensuring consistent high quality at all times.

U.S.A
Moffat Inc
 3765 Champion Boulevard
 Winston-Salem
 North Carolina 27105
 Call Free 1800 551 8795
 Ph 336-661 0257
 Fax 336-661 9546
 Email sales@moffat.com
 www.moffat.com

Canada
Serve Canada
 22 Ashwarren Road
 Downview
 Ontario, M3J 1Z5
 Ph 416-631 0601
 Fax 416-631 0315
 Email info@servecanada.com

Australia
Moffat Pty Limited
 740 Springvale Rd
 Mulgrave
 Victoria 3170
 Australia
 Ph 03-9518 3888
 Fax 03-9518 3833
 Email vsales@moffat.com.au
 www.moffat.com.au

New Zealand
Moffat Limited
 16 Osborne St
 PO Box 10-001
 Christchurch
 New Zealand
 Ph 03-389 1007
 Fax 03-389 1276
 Email sales@moffat.co.nz
 www.moffat.co.nz

United Kingdom
Blue Seal Limited
 Units 6-7 Mount St
 Business Park
 Birmingham B7 5QU
 England
 Ph 0121-327 5575
 Fax 0121-327 9711
 Email sales@blue-seal.co.uk
 www.blue-seal.co.uk

