











# MOFFAT® E27MS

## Full Size Electric Convection Oven

-  Commercial construction
-  3 full pan capacity
-  2 wire racks supplied
-  Bi-direction reversing fan system
-  15 amp plug-in (NEMA 6-15P)
-  60 minute bake timer
-  Stainless steel outer
-  Stainless steel door with full viewing window
-  Heavy duty stainless steel door handle
-  Insulated porcelain inner
-  Internal lighting



E27MS



Order Toll Free 1800 551 8795

### E27MS

Unit shall be a Moffat electrically heated Turbofan convection oven E.T.L. listed (UL Std 197) and NSF-4 listed. The oven shall have a one piece vitreous porcelain enamel oven liner, stainless steel top and sides with single stainless steel door and full viewing window. Oven liner shall be insulated on all sides and have capacity for three full size sheet pans. The oven shall have a bi-direction single reversing fan system for oven bake circulation. The oven shall be controlled by a mechanical thermostat with a range from 120°F to 480°F, a 60 minute bake timer, and oven light switch. Oven shall be able to be bench mounted on 4" legs. Oven shall be fitted with a NEMA 6-15P cordset.

# MOFFAT® E27MS

## Full Size Electric Convection Oven

### CONSTRUCTION

Stainless steel top and sides  
Porcelain oven interior  
Toughened twin pane door glass  
Strong and stylish door handle  
3 full pan capacity (2 wire racks included)  
Fully insulated  
Stainless steel control panel with overlay  
Fully enclosed motor at rear

### CONTROLS

On/off switch  
Mechanical thermostat, variable between  
120°F to 480°F  
Bi-direction reversing fan system  
Oven light  
60 minute bake timer

### CLEANING AND SERVICING

Fully removable racks and fan baffle  
Easy clean surfaces  
Access to all controls from front panel  
No tools to replace lamps  
Removable gaskets - no tools required

### SPECIFICATIONS

#### Electrical requirements

208V, 50/60Hz, 1P+N+E, 3.0kW, 14.4A  
220-240V, 50/60Hz, 1P+N+E, 3.0kW, 12.5A  
NEMA 6-15P cordset fitted

#### External Dimensions

Width 37 1/4" (945mm)  
Height 16 7/8" (430mm)  
Depth 28 1/2" (725mm)

#### Internal Dimensions

Width 27 3/8" (695mm)  
Height 11 1/4" (285mm)  
Depth 19 7/8" (505mm)

#### Oven Volume

3.5 ft<sup>3</sup> (0.10m<sup>3</sup>)

#### Oven Rack Dimensions

Depth 18" (460mm)  
Width 26" (660mm)

#### Nett Weight

130lbs (59kg)

#### Packing Data

227lbs (103kg)  
16.25ft<sup>3</sup> (0.46m<sup>3</sup>)  
Width 38 3/4" (985mm)  
Height 22" (560mm)  
Depth 33" (840mm)

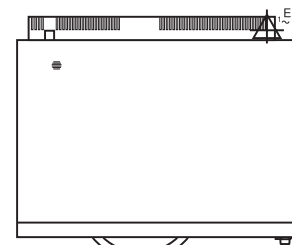
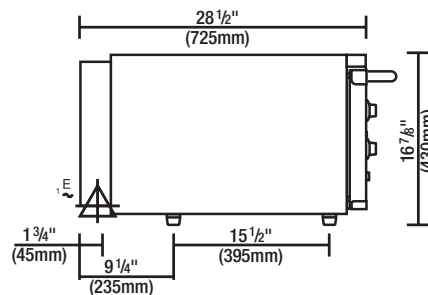
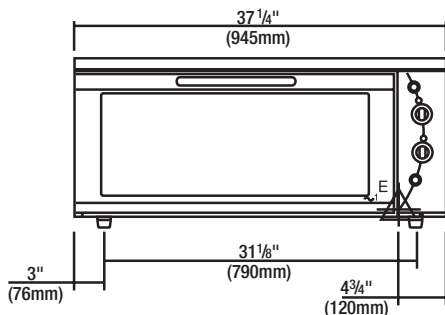

DOOR SWING 13 3/8" (337mm)

MOFFAT®

www.moffat.com

### U.S.A

#### Moffat Inc

3765 Champion Boulevard  
Winston-Salem  
North Carolina 27105  
Call Free 1800 551 8795  
Ph 336-661 0257  
Fax 336-661 9546  
Email sales@moffat.com  
www.moffat.com

### Canada

#### Serve Canada

22 Ashwarren Road  
Downview  
Ontario M3J1Z5  
Ph 416-631 0601  
Fax 416-631 7687  
Email info@servecanada.com

### Australia

#### Moffat Pty Limited

740 Springvale Rd  
Mulgrave  
Victoria 3170  
Australia  
Ph 03-9518 3888  
Fax 03-9518 3833  
Email vsales@moffat.com.au  
www.moffat.com.au

### New Zealand

#### Moffat Limited

16 Osborne St  
PO Box 10-001  
Christchurch  
New Zealand  
Ph 03-389 1007  
Fax 03-389 1276  
Email sales@moffat.co.nz  
www.moffat.co.nz

### United Kingdom

#### Blue Seal Limited

Units 6-7 Mount St  
Business Park  
Birmingham B7 5QU  
England  
Ph 0121-327 5575  
Fax 0121-327 9711  
Email sales@blue-seal.co.uk  
www.blue-seal.co.uk



**ISO 9001**  
All Turbofan products are designed and manufactured by Moffat Ltd using the internationally recognised ISO 9001 quality management system, covering design, manufacture and final inspection, ensuring consistent high quality at all times.

