











# MOFFAT® E35

## Full Size Electric Convection Oven

-  6 sheet pan capacity  
(8 with cookie kit option)
-  Stainless steel outer
-  Porcelain inner
-  Solid state thermostat
-  Plug in door seal
-  60 minute bake timer
-  Hot reversing air system
-  Time driven steam system
-  2 speed fan
-  Field reversible door
-  Single or 3 phase



E35



Order Toll Free 1800 551 8795

### E35

Unit shall be a Moffat electrically heated Turbofan convection oven, E.T.L listed (UL Std 197, NSF-4). The oven shall have a one piece vitreous porcelain enamel oven liner, stainless steel exterior, twin pane field reversible full view glass door with ventilation top and bottom, with the outer panel hinged for cleaning. A two speed auto reversing fan shall evenly circulate air internally. Heating shall be accomplished via electric elements surrounding the fan. The oven shall be controlled by a solid state thermostat accurate to  $\pm 2^{\circ}\text{F}$ , range  $150^{\circ}\text{F}$  to  $550^{\circ}\text{F}$ , have a 60 minute bake timer, push button steam injection system, fan speed control and oven vent control. Oven shall be able to be bench mounted on 4" legs or on Moffat's A26 stand or E85-HLD proofer and holding cabinet, rated for zero clearance left and rear.

## Full Size Electric Convection Oven

### CONSTRUCTION

Top and sides stainless steel  
 Porcelain oven interior  
 Stay cool twin pane glass door  
 (outer surface 163°F when oven operating at 356°F)  
 Interlocking door handle  
 Stainless steel oven racking system with runners for wire racks or full size sheet pans  
 Insulated all round for zero clearance left side and rear  
 Porcelain control panel  
 Field reversible door

### CONTROLS

Electronic thermostat variable from 150°F to 550°F ± 2°F  
 1 hour bake timer with buzzer  
 Timed water injected steam  
 2 speed fan (700rpm-1400rpm)  
 On/off switch  
 Hot reversing air system  
 High limit safety

### CLEANING AND SERVICING

Access to all parts from the front and right side of the unit  
 Easy clean surfaces  
 Fully removable oven racking system  
 Door outer glass hinged for cleaning access

### OPTIONS

Fully insulated stainless steel door with twin pane glass viewing window  
 A26 stand  
 E85-A-8-HLD or E85-A-12-HLD Proofers and Holding Cabinets  
 Sheet pans, wire racks  
 Specialist side racks for cookies

### SPECIFICATIONS

#### Electrical Requirements

208V 1ph 11.2kW 53.7A  
 220-240V 1ph 12.5kW 52A  
 208V 3ph+E 11.2kW L1 31.1A  
 L2 31.1A  
 L3 31.1A  
 220-240V 3ph+E 12.5kW L1 30.1A  
 L2 30.1A  
 L3 30.1A

#### Water

<sup>3</sup>/<sub>4</sub>" thread  
 80psi max inlet pressure  
 20psi min inlet pressure

#### External Dimensions

Width 34<sup>5</sup>/<sub>8</sub>" (880mm)  
 Height 31<sup>1</sup>/<sub>2</sub>" (800mm)  
 Depth 34<sup>5</sup>/<sub>8</sub>" (880mm)

#### Internal Dimensions

Width 18" (460mm)  
 Height 28" (710mm)  
 Depth 26" (660mm)

#### Oven Rack Dimensions

Width 18" (460mm)  
 Depth 26" (660mm)

#### Nett Weight

330lbs (150kg)

#### Packing Data

441lbs (200kg)  
 33.8ft<sup>3</sup> (0.96m<sup>3</sup>)  
 Width 39<sup>1</sup>/<sub>2</sub>" (1001mm)  
 Height 39" (990mm)  
 Depth 38" (965mm)

#### Clearances

Left side -  
 Right side 3" (75mm)  
 Rear -  
 Top -

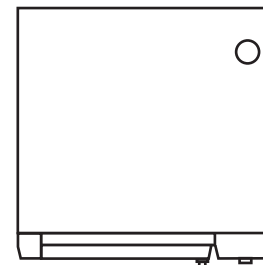
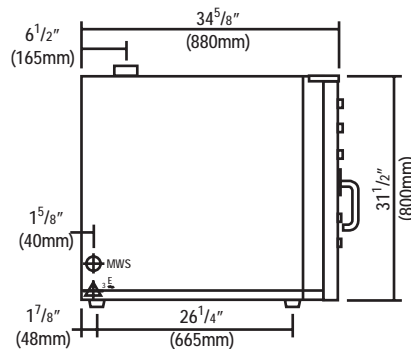
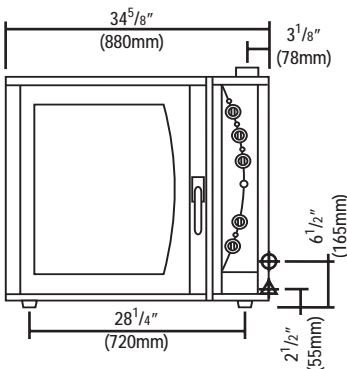

Door swing 24<sup>3</sup>/<sub>4</sub>" (630mm)

### U.S.A

**Moffat Inc**  
 3765 Champion Boulevard  
 Winston-Salem  
 North Carolina 27105  
 Call Free 1800 551 8795  
 Ph 336-661 0257  
 Fax 336-661 9546  
 Email sales@moffat.com  
 www.moffat.com

### Canada

**Serve Canada**  
 22 Ashwarren Road  
 Downview  
 Ontario, M3J 1Z5  
 Ph 416-631 0601  
 Fax 416-631 0315  
 Email info@servecanada.com

### Australia

**Moffat Pty Limited**  
 740 Springvale Rd  
 Mulgrave  
 Victoria 3170  
 Australia  
 Ph 03-9518 3888  
 Fax 03-9518 3833  
 Email vsales@moffat.com.au  
 www.moffat.com.au

### New Zealand

**Moffat Limited**  
 16 Osborne St  
 PO Box 10-001  
 Christchurch  
 New Zealand  
 Ph 03-389 1007  
 Fax 03-389 1276  
 Email sales@moffat.co.nz  
 www.moffat.co.nz

### United Kingdom

**Blue Seal Limited**  
 Units 6-7 Mount St  
 Business Park  
 Birmingham B7 5QU  
 England  
 Ph 0121-327 5575  
 Fax 0121-327 9711  
 Email sales@blue-seal.co.uk  
 www.blue-seal.co.uk



**ISO 9001**  
 All Turbofan products are designed and manufactured by Moffat Ltd using the internationally recognised ISO 9001 quality management system, covering design, manufacture and final inspection, ensuring consistent high quality at all times.

