

Project _____

Item # _____

Quantity _____



GLOBE FOOD EQUIPMENT COMPANY

80 Quart Mixer

SP80PL



SP80PL 80 Quart Mixer

Model

- SP80PL - 80 Quart Mixer



Standard Features

- 3 HP custom built motor
- Four fixed speeds
- High torque direct drive transmission
- Oil bath transmission
- Heat-treated hardened steel alloy gears and shafts
- Thermal overload protection
- Power bowl lift
- Automatic shut off if speeds are changed during operation
- Rigid cast iron body
- Stainless steel bowl guard with built in ingredient chute
- NSF approved enamel gray paint
- Front mounted controls
- 15 minute timer
- Industry standard #12 attachment hub
- Safety interlocked bowl guard and bowl lift
- Non-slip rubber feet

Standard Accessories

- 80 quart stainless steel bowl
- Flat beater (aluminum)
- Stainless steel wire whip
- Spiral dough hook (aluminum)
- Bowl truck

Optional Attachments/Accessories

- Vegetable slicer for #12 hub
- Shredder/grater for #12 hub
- Meat grinder for #12 hub
- Aileron (Wing) Whip
- 40 quart adapter kit
- Bowl scraper

Standard Warranty

- Two-years parts and one-year labor

Approved By: _____

Date: _____



GLOBE FOOD EQUIPMENT COMPANY

www.globeslicers.com

2153 Dryden Rd
Dayton, OH 45439
Phone: 937-299-5493
Phone: 800-347-5423
Fax: 937-299-4147



80 Quart Mixer

SP80PL

Specifications

Motor: 3 HP, grease packed ball bearing, air cooled, 208/60/3, 12 amps. Thermal overload protection (automatic reset).

Finish: NSF approved enamel gray paint.

Capacity: 80 quart (75.7 liter) bowl.

Transmission: Direct drive, fixed speed transmission is made of heat treated, hardened alloy, precision milled gears that operate the planetary action and provide high torque mixing power. The gears are continuously lubricated in an oil bath, and all shafts are mounted in ball bearings.

Safety Interlocks: The bowl guard and power bowl lift are interlocked. The mixer will automatically shut down when the guard is opened or the bowl is lowered.

Cord: Hard wired.

Dimensions:

Foot Print = 30" x 36"
(76.2cm x 91.4cm)
Overall Length = 48" (121.9cm)
Overall Width = 30" (76.2cm)
Overall Height = 62" (157.5cm)

Agitator Speeds (RPMs):

First	60
Second	105
Third	176
Fourth	310

Attachment Speeds (RPMs):

First	67
Second	118
Third	198
Fourth	349

Standard Equipment: Standard equipment includes a 80 quart #304 series stainless steel bowl, aluminum spiral dough hook, stainless steel wire whip, aluminum flat beater, stainless steel bowl guard with built in ingredient chute, 15 minute timer, bowl truck, and #12 attachment hub. A power bowl lift raises and lowers the bowl as well as locking in place at the top and bottom positions.

Shipping Information:

Freight Class: 85
Net Weight: 1,003 lbs. (455 kg)
Shipping Weight: 1,270 lbs. (575 kg)
Shipping Dimensions:
48"W x 48"D x 76"H
(121.9 x 121.9cm x 193cm)
Cartons are affixed to a skid (pallet). The weight and dimensions of this skid are included above and may vary from shipment to shipment.

Optional Accessories:

XXACC40-80 Adapter Kit includes a 40 quart bowl, wire whip, dough hook, flat beater, and bowl adapter to adapt 80 quart mixer to a 40 quart capacity.

XXAWHIP-20 Aileron (Wing) Whip

Optional Attachments:

XMCA-SS Meat Grinder Assembly (Polished stainless steel cylinder, worm gear, ring, and pan. Includes knife, 3/16" plate, stainless steel pan, and pusher.)

Chopper Plate Sizes Available:

CP02-12	1/16"	(2mm)
CP04-12	5/32"	(4mm)
CP05-12	3/16"	(5mm)
CP06-12	1/4"	(6mm)
CP08-12	5/16"	(8mm)
CP10-12	3/8"	(10mm)
CP12-12	1/2"	(12mm)
CP14-12	9/16"	(14mm)
CP16-12	5/8"	(16mm)
CP18-12	11/16"	(18mm)
CP00-12	Stuffing Plate	
XST12	1/2" stuffing tube (sheep)	
XST34	3/4" stuffing tube (hog)	

XVSGH 9" Slicer/Shredder/Grater Housing Only (*no plates included - must select from plates below*)

XASP Adjustable slicing plate
XPH Plate holder - *only 1 required

Shredding/Grating Plates:

XSP332*	3/32"	(2.3mm)
XSP316*	3/16"	(4.7mm)
XSP14*	1/4"	(6.3mm)
XSP516*	5/16"	(7.9mm)
XSP12*	1/2"	(12.7mm)
XGP*	Grating plate	

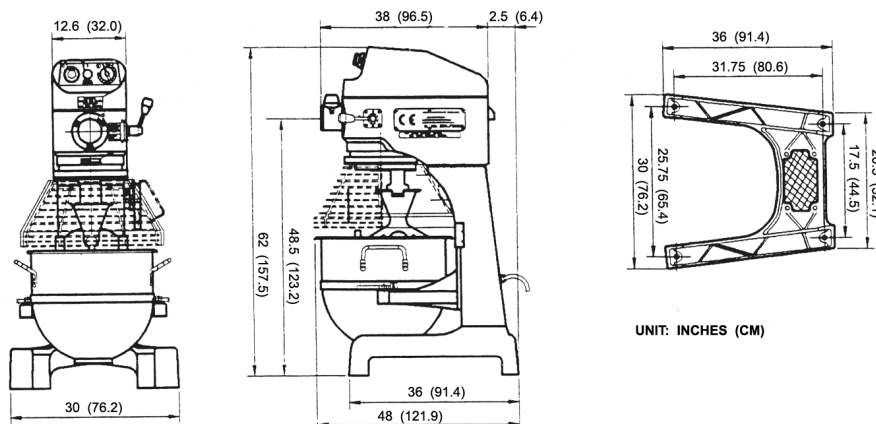

UNIT: INCHES (CM)



GLOBE FOOD EQUIPMENT COMPANY

www.globeslicers.com

2153 Dryden Rd
Dayton, OH 45439
Phone: 937-299-5493
Phone: 800-347-5423
Fax: 937-299-4147

Specifications are subject to change without notice.

Printed in U.S.A. 04-2010