

TWO DOOR PIZZA PREPARATION UNIT

JPP-6809
20 cu. ft., 9 pans



Factory Options:

Model No. (with factory option)	Description
JPP-6809-2D-L	2 Drawers, left (each drawers fits 2 full size 12" x 20" pan)
JPP-6809-2D-R	2 Drawers, right (each drawers fits 2 full size 12" x 20" pan)
JPP-6809-4D	4 Drawers (each drawers fits 2 full size 12" x 20" pan)



JPP-6809-2D-R



NSF/ANSI Standard 7



C LISTED US

GENERAL INFORMATION

Dimensions: 68.0" (W) x 31.3" (D) x 43.5" (H)

Doors: 2

Shelves: 2

Cubic Ft.: 20

Shelf Size: 23.4"x24.4"

Unit Weight: 465 lbs.

Ship Weight: 500 lbs.

TECHNICAL DATA

Refrigerant: R-134A

Start Amps: 9.7

Run Amps: 8.1

Horsepower: 1/3

Volts: 115

Compressors: 1





JPP-6809

Two Door Pizza Preparation Unit

ELECTRICAL PLUG



*NEMA 5-15P plug
5-15R receptacle required*

DIMENSIONAL INFORMATION

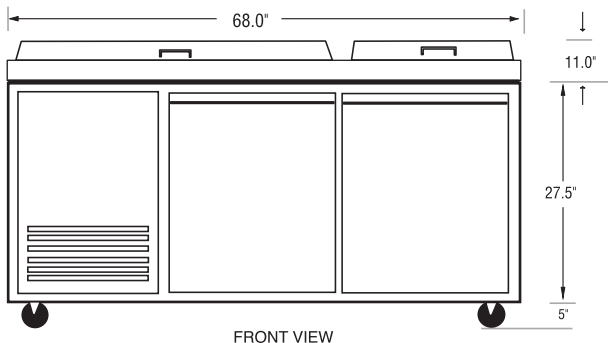
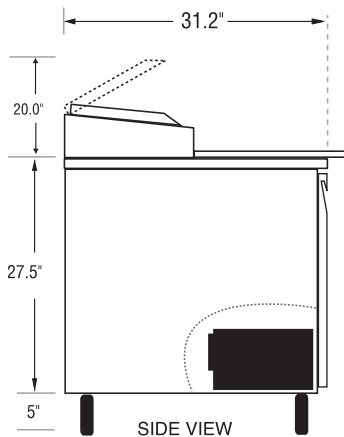

FEATURES & BENEFITS

- Stainless steel interior & exterior
- Forced air system with no need for defrost
- Recessed door handles
- Stainless steel catch tray
- 1" insulated condiment lid
- Reinforced door hinges
- Side-mounted compressor and evaporator coil
- Slide out refrigeration system for quick service
- CFC-free R-134a refrigerant
- 2.5" thick foamed-in-place polyurethane insulation
- 1 vinyl-coated wire shelves per door
- Hot gas evaporative condensate pan
- Fully coved interior corners
- 5" casters included
- Clear, 4" deep polycarbonate pans included
- Automatic door closure with 90° hold open feature
- Snap-in magnetic door gaskets
- 18" removable cutting board included
- *2 year parts & labor and 5 year compressor warranty*

MATERIALS

- INTERIOR: Stainless steel interior walls, floor, and ceiling
Vinyl-coated wire shelves
- EXTERIOR: Stainless steel sides and doors

