



Reaching New Heights

PROJECT _____

QTY. _____ ITEM NO _____

Date Modified 6/25/08

Two Door Mega Top Sandwich Preparation Unit



JMP-6024
60.0" wide, 15 cu.ft.

Stainless steel interior & exterior standard!
Front breathing!
The most durable condiment lid in the industry!

STANDARD FEATURES:

- Front Breathing
- Thermostatic Control
- Stainless Steel Catch Tray under pans
- CFC-free R-134a Refrigerant
- 2 Vinyl-Coated Wire Shelves
- 5" Casters Included
- Reinforced Door Hinges
- Fully Coved Interior Corners
- Self-Contained Rear Mounted Refrigeration System
- 2.5" Thick Foamed-in-place Polyurethane Insulation
- Fully-Recessed Door Handles
- Automatic Door Closure with 90° Hold Open Feature
- Evaporative Hot Gas Condensate Pan
- Snap-In Magnetic Door Gasket
- Assembled in USA

MATERIALS:

INTERIOR: Stainless steel interior walls, floor, and ceiling.
Vinyl-coated wire shelves.

EXTERIOR: Stainless steel worktop.
Stainless steel sides and doors.



NSF/ANSI Standard 7



ACCREDITED
ISO 17025:2005 Certified

DIMENSIONAL DATA

| Model No. | L | D | H | Cu.Ft. | Lids | Pans | H/P | Volt | Amp. | NEMA | Shipping Wt. |
|-----------|-------|-------|-------|--------|------|------|-----|----------|------|-------|--------------|
| JMP-6024 | 60.0" | 33.5" | 45.2" | 15 | 2 | 24 | 1/2 | 115/60/1 | 8.9 | 5-15P | 435 |



Mega Top Sandwich Prep Unit

JMP-6024

Description: Two door mega top sandwich prep unit, 15 cu. ft

Features & Benefits

Stainless steel interior and exterior for greater durability, construction and appearance.

Self-contained **rear-mounted refrigeration** with high humidity coated fin coil evaporator.

- Holds 33° F to 41° F for refrigerator

2.5" thick, foamed-in-place polyurethane high density insulation.

24 poly-carbonate, 1/6 size pans.

5" casters included- for easy mobility and installation.

Ten inch full length removable cutting board.

Stainless steel top.

Reinforced hinges and self-closing doors with 90 degree hold-open feature and fully-recessed handles.

Hot gas evaporative condensate pan - no floor drain required!

PAN CONFIGURATION

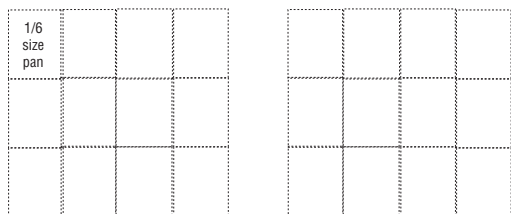

Optional

Fits 1 full size 12"x20" pan or 2 half size 12"x10" pans in place of 6 sixth size pans. (Full size and half size pans not included)

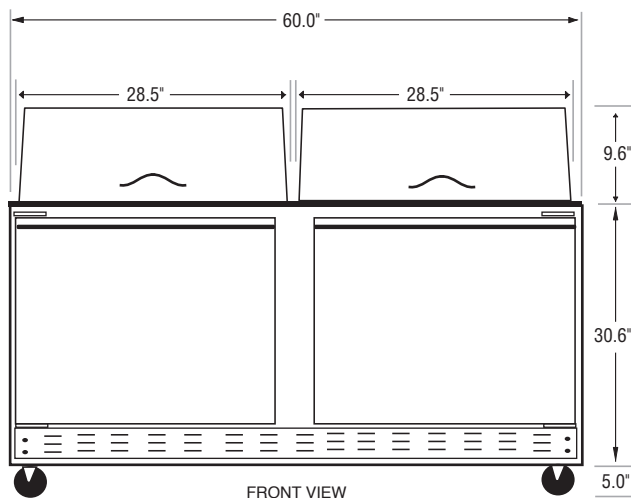
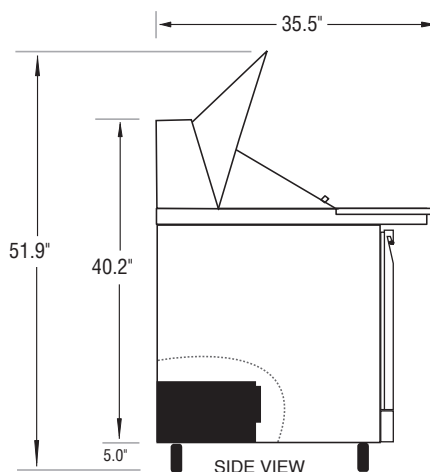
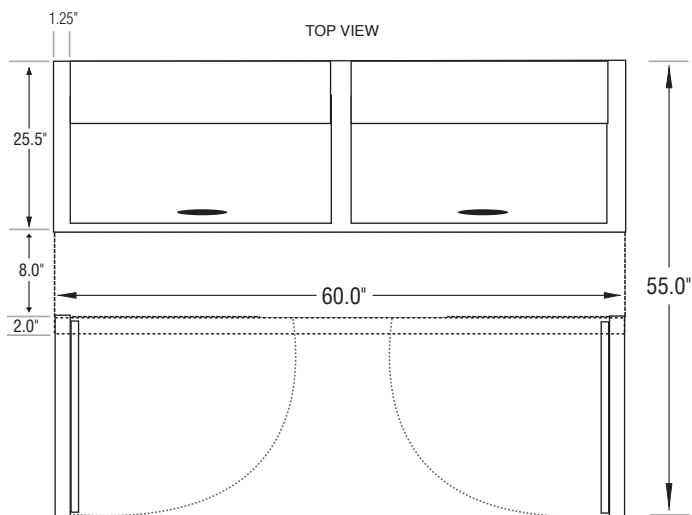

NEMA 5-15P plug
5-15R receptacle required

General Information

Cubic Ft.: 15

Shelf Size: 17.5" x 22.9"

Pans: 24

#Lids: 2

Exterior: Stainless

Unit Weight: 405 lbs.

Interior: Stainless

Ship Weight: 435 lbs.

Technical Data

Refrigerant: R-134a

Volts: 115

Start Amps: 10.8

#Compressors: 1

Run Amps: 8.9

Cord Length: 82 in.

Horsepower: 1/2

SPECIFICATIONS SUBJECT TO CHANGE WITHOUT NOTICE