

PROJECT _____

QTY. _____ ITEM NO _____



Reaching New Heights

Date Modified 6/2/08

One Door Mega Top Sandwich Preparation Unit



JMP-2712
27.5" wide, 6 cu.ft.

Stainless steel interior & exterior standard!
Front breathing!
The most durable condiment lid in the industry!

STANDARD FEATURES:

- Front Breathing
- Thermostatic Control
- Stainless Steel Catch Tray under pans
- CFC-free R-134a Refrigerant
- 1 Vinyl-Coated Wire Shelf
- 5" Casters Included
- Reinforced Door Hinges
- Fully Coved Interior Corners
- Self-Contained Rear Mounted Refrigeration System
- 2.5" Thick Foamed-in-place Polyurethane Insulation
- Fully-Recessed Door Handle
- Automatic Door Closure with 90° Hold Open Feature
- Evaporative Hot Gas Condensate Pan
- Snap-In Magnetic Door Gasket
- Assembled in USA

MATERIALS:

INTERIOR: Stainless steel interior walls, floor, and ceiling.
Vinyl-coated wire shelf.

EXTERIOR: Stainless steel worktop.
Stainless steel sides and door.



NSF/ANSI Standard 7



ACCREDITED

ISO 17025:2005 Certified

DIMENSIONAL DATA

Model No.	L	D	H	Cu.Ft.	Lids	Pans	H/P	Volt	Amp.	NEMA	Shipping Wt.
JMP-2712	27.5"	33.5"	45.2"	6	1	12	1/4	115/60/1	5.24	5-15P	260



Mega Top Sandwich Prep Unit JMP-2712

Description: One door mega top sandwich prep unit, 6 cu. ft

Features & Benefits

Stainless steel interior and exterior for greater durability, construction and appearance.

Self-contained **rear-mounted refrigeration** with high humidity coated fin coil evaporator.

- Holds 33° F to 41° F for refrigerator

2.5" thick, foamed-in-place polyurethane high density insulation.

Nine poly-carbonate, 1/6 size pans and three poly-carbonate, 1/9 size pans.

5" casters included- for easy mobility and installation.

Ten inch full length removable cutting board.

Stainless steel top.

Reinforced hinges and self-closing door with 90 degree hold-open feature and fully-recessed handles.

Hot Gas evaporative condensate pan - no floor drain required!

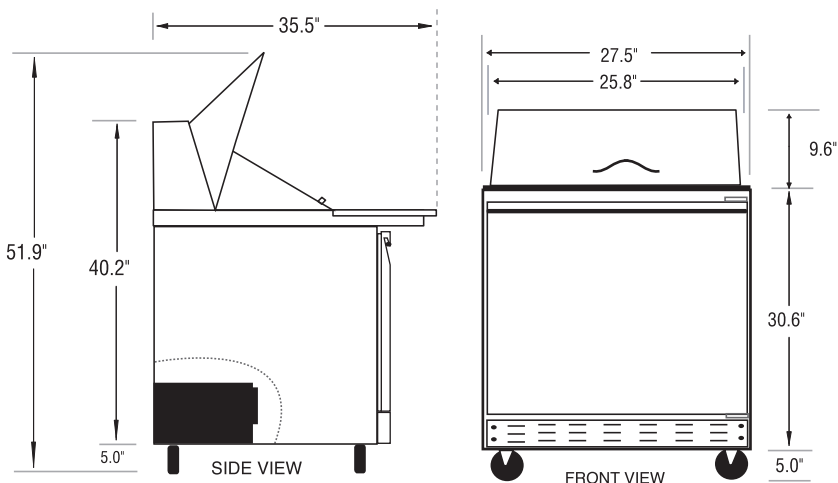
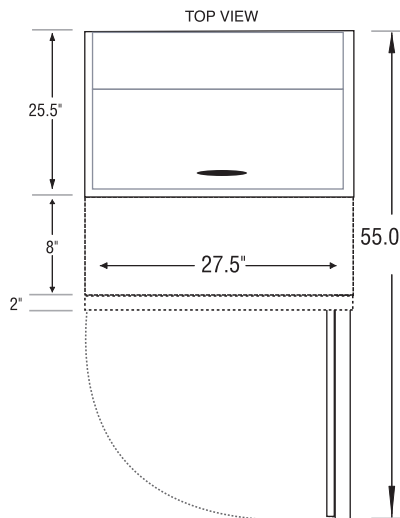

Optional

Fits 1 full size 12"x20" pan or 2 half size 12"x10" pans in place of 6 sixth size pans. (Full size and half size pans not included)

PAN CONFIGURATION

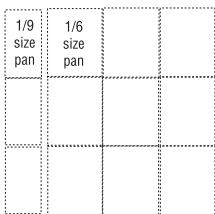

NEMA 5-15P plug
5-15R receptacle required

General Information

Cubic Ft.: 6

Shelf Size: 17.5" x 22.9"

Pans: 12

#Lids: 1

Exterior: Stainless

Unit Weight: 225 lbs.

Interior: Stainless

Ship Weight: 260 lbs.

Technical Data

Refrigerant: R-134a

Volts: 115

Start Amps: 7.86

#Compressors: 1

Run Amps: 5.24

Cord Length: 82 in.

Horsepower: 1/4