



*Reaching New Heights*

Date Modified 6/2/08

**Six Half Door Freezer**



**JHD-61F**  
61 cu.ft., 3 section



Patent # **D445, 159S**  
**D445, 160S**  
**D445, 161S**

- Stainless steel interior & exterior standard!***
- Recessed door handles!***
- Exterior digital temperature controls!***
- Convenient low box height design!***
- Energy saving half door design!***

**STANDARD FEATURES:**

- Recessed Door Handles
- Self-Contained Top Mounted Refrigeration System
- 2 Vinyl-Coated Wire Shelves per Door
- 5" Casters Included
- Specifically Designed 76.2" High for Easy Mobility and Installation
- Reinforced Door Hinges
- CFC-free R-404a Refrigerant
- Evaporative Electric Condensate Pan
- Fully Coved Interior Corners
- Automatic Door Closure with 90° Hold Open Feature
- Door Locks
- 2.5" Thick Foamed-in-place Polyurethane Insulation
- Exterior Digital Temperature Control
- Snap-In Magnetic Door Gaskets
- Assembled in USA

**MATERIALS:**

INTERIOR: Stainless steel interior walls, floor, and ceiling.  
Vinyl-coated wire shelves.  
EXTERIOR: Stainless steel sides and doors



**DIMENSIONAL DATA:**

Model No.	L	D	H	Doors	Cu.Ft.	Shelves	H/P	Volt	Amp.	NEMA	Ship Wt.
JHD-61F	74.8"	31.8"	76.2"	6	61	12	3/4, 1/2	220/60/1	7.9	6-15P	750



## Solid Door Freezer

# JHD-61F

Description: Six solid half door freezer, 61 cu. ft

### Features & Benefits

**Stainless steel interior and exterior for greater durability, construction and appearance.**

**Recessed door handles with plastic door handle gaskets for ease of use.**

**Self-contained top mounted refrigeration system and high humidity coated fin coil evaporator.**

- Holds -10° F to 10° F as freezer

**Automatic interior light in both freezer sections. Cabinet is partitioned to keep one section at a separate temperature than the section.**

**Exterior LED temperature display with digital controls. Temperature setting is easy, fast and accurate.**

**Micro-controller with adjustable temperature variance, automatic defrost intervals, setpoint limits, and parameter locking functions.**

**12 adjustable vinyl-coated steel wire shelves.**

**5" casters standard. Easy mobility and installation.**

**Convenient and energy-efficient half-door design.**

**Electric condensate evaporator - no floor drain required!**

**Reinforced door hinges with 90 degree hold open feature.**

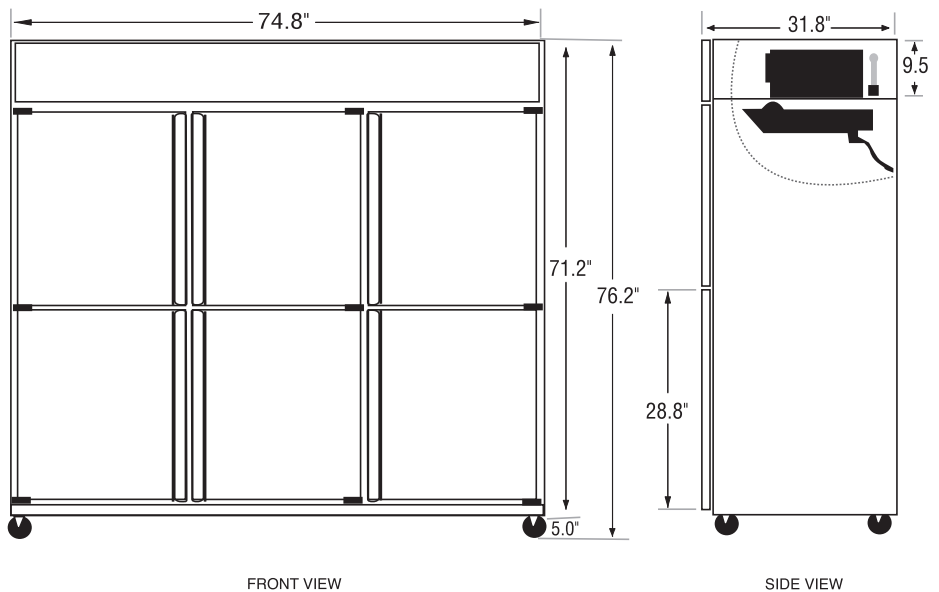
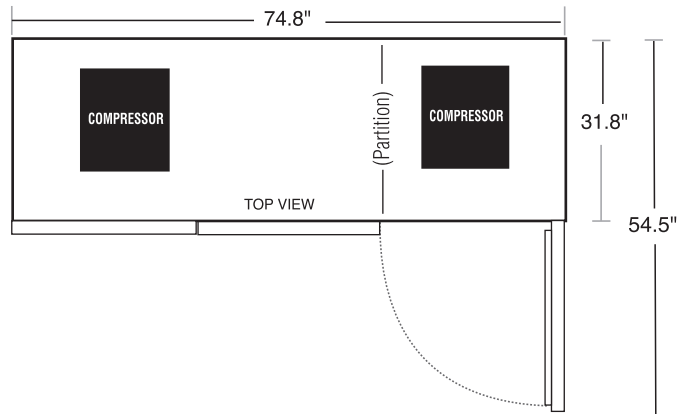

NEMA 6-15P plug  
6-15R receptacle required

### General Information

**Cubic Ft.:** 61

**Half Doors:** 6

**Exterior:** Stainless

**Interior:** Stainless

**Shelf Size:** 24.75"x20.5" (x4) 24.5" x 22" (x8)

**Unit Weight:** 715 lbs.

**Ship Weight:** 750 lbs.

### Technical Data

**Refrigerant:** R-404a

**Start Amps:** 11.85

**Run Amps:** 7.90

**Horsepower:** 3/4, 1/2

**Volts:** 220

**#Compressors:** 2

**Cord Length:** 82 in.