



Reaching New Heights

Date Modified 6/2/08

Six Half Door Refrigerator/Freezer



JHD-61DT

61 cu.ft., 3 section



Patent # **D445, 159S**
D445, 160S
D445, 161S

- Stainless steel interior & exterior standard!***
- Recessed door handles!***
- Exterior digital temperature controls!***
- Convenient low box height design!***
- Energy saving half door design!***

STANDARD FEATURES:

- Recessed Door Handles
- Self-Contained Top Mounted Refrigeration System
- 2 Vinyl-Coated Wire Shelves per Door
- 5" Casters Included
- Specifically Designed 76.2" High for Easy Mobility and Installation
- Reinforced Door Hinges
- CFC-free R-134a & R-404a Refrigerant
- Evaporative Electric Condensate Pan
- Fully Coved Interior Corners
- Automatic Door Closure with 90° Hold Open Feature
- Door Locks
- 2.5" Thick Foamed-in-place Polyurethane Insulation
- Exterior Digital Temperature Control
- Snap-In Magnetic Door Gaskets
- Assembled in USA

MATERIALS:

INTERIOR: Stainless steel interior walls, floor, and ceiling.
Vinyl-coated wire shelves.
EXTERIOR: Stainless steel sides and doors



NSF/ANSI Standard 7



ACCREDITED
ISO 17025:2005 Certified

DIMENSIONAL DATA:

Model No.	L	D	H	Doors	Cu.Ft.	Shelves	H/P	Volt	Amp.	NEMA	Ship Wt.
JHD-61DT	74.8"	31.8"	76.2"	6	40, 21	12	1/3, 1/2	115/60/1	12.42	5-20P	720



Solid Door Refrigerator/Freezer

JHD-61DT

Description: Six solid half door REF(4dr)FRE(2dr), 61 cu. ft.

Features & Benefits

Stainless steel interior and exterior for greater durability, construction and appearance.

Recessed door handles with plastic door handle gaskets for ease of use.

Self-contained top mounted refrigeration system and high humidity coated fin coil evaporator.

- Holds -10° F to 10° F as freezer
- Holds 30° F to 45° F as refrigerator

Automatic interior lights in refrigerator and freezer sections.

Exterior LED temperature display with digital controls. Temperature setting is easy, fast and accurate.

Micro-controller with adjustable temperature variance, automatic defrost intervals, setpoint limits, and parameter locking functions.

12 adjustable vinyl-coated steel wire shelves.

5" casters standard. Easy mobility and installation.

Convenient and energy-efficient half-door design.

Electric condensate evaporator - no floor drain required!

Reinforced door hinges with 90 degree hold open feature.

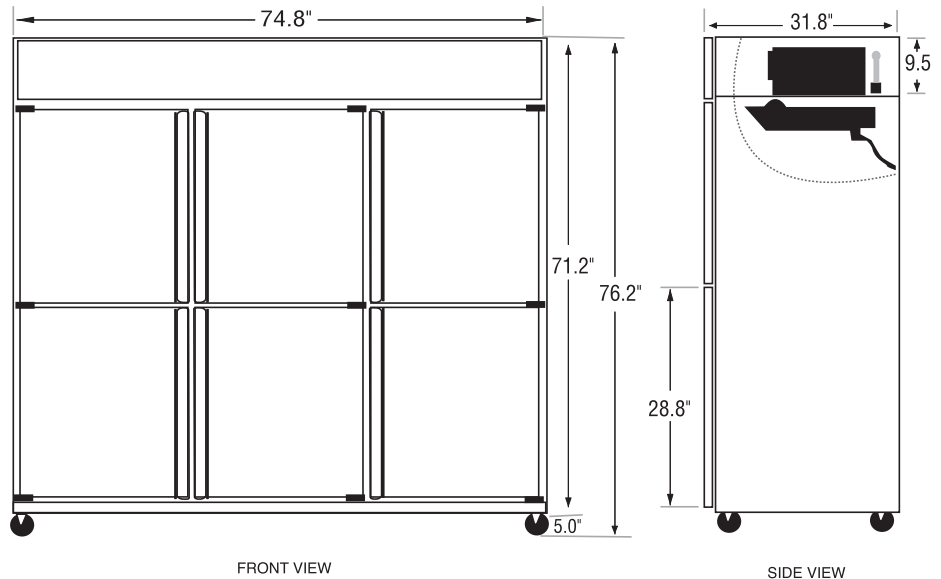
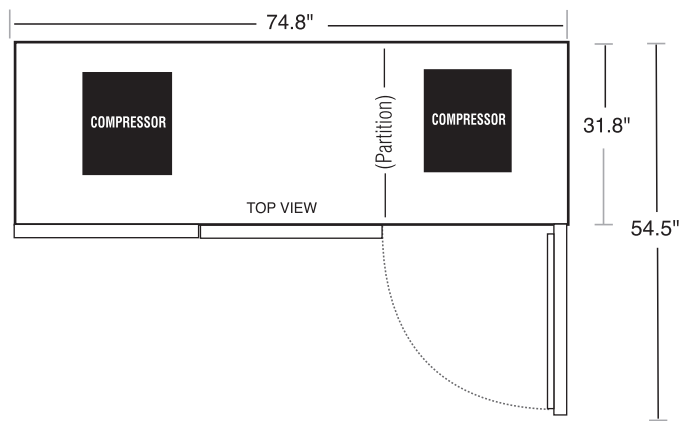

FACTORY OPTIONS

Suffix 1	Suffix 2	Description	Add to List
-4G	(REF only)	4 glass doors, light switch	\$2100
-2G	(REF only)	1 glass doors, light switch	\$1050
	-T	Top 2 glass doors	
	-L	Left 2 glass doors	

More glass door configurations available, see price list



NEMA 5-20P plug
5-20R receptacle required

General Information

Cubic Ft.: 40,21

Half Doors: 6

Exterior: Stainless

Interior: Stainless

Shelf Size: 24.75"x20.5" (x4) 24.5" x 22" (x8)

Unit Weight: 690 lbs.

Ship Weight: 720 lbs.

Technical Data

Refrigerant: R-404A & R-134A

Start Amps: 18.63

Run Amps: 12.42

Horsepower: 1/3,1/2

Volts: 115

#Compressors: 2

Cord Length: 82 in.