



Reaching New Heights

Date Modified 6/2/08

Four Half Door Refrigerator



JHD-40R
40 cu.ft., 2 section



Patent # **D445, 159S**
D445, 160S
D445, 161S

Stainless steel interior & exterior standard!
Recessed door handles!
Exterior digital temperature controls!
Convenient low box height design!
Energy saving half door design!

STANDARD FEATURES:

- Recessed Door Handles
- Self-Contained Top Mounted Refrigeration System
- 2 Vinyl-Coated Wire Shelves per Door
- 5" Casters Included
- Specifically Designed 76.2" High for Easy Mobility and Installation
- Reinforced Door Hinges
- CFC-free R-134a Refrigerant
- Evaporative Electric Condensate Pan
- Fully Coved Interior Corners
- Automatic Door Closure with 90° Hold Open Feature
- Door Locks
- 2.5" Thick Foamed-in-place Polyurethane Insulation
- Exterior Digital Temperature Control
- Snap-In Magnetic Door Gaskets
- Assembled in USA

MATERIALS:

INTERIOR: Stainless steel interior walls, floor, and ceiling.
Vinyl-coated wire shelves.
EXTERIOR: Stainless steel sides and doors



NSF/ANSI Standard 7



ACCREDITED
ISO 17025:2005 Certified

DIMENSIONAL DATA:

Model No.	L	D	H	Doors	Cu.Ft.	Shelves	H/P	Volt	Amp.	NEMA	Ship Wt.
JHD-40R	49.6"	31.8"	76.2"	4	40	8	1/3	115/60/1	6.32	5-15P	490



Solid Door Refrigerator

JHD-40R

Description: Four solid half door refrigerator, 40 cu. ft

Features & Benefits

Stainless steel interior and exterior for greater durability, construction and appearance.

Recessed door handles with plastic door handle gaskets for ease of use.

Self-contained top mounted refrigeration system and high humidity coated fin coil evaporator.

- Holds 30° F to 45° F as refrigerator

Automatic interior lights.

*Exterior LED temperature display with digital controls. **Temperature setting is easy, fast and accurate.***

Micro-controller with adjustable temperature variance, setpoint limits, and parameter locking functions.

8 adjustable vinyl-coated steel wire shelves.

*5" casters standard. **Easy mobility and installation.***

Convenient and energy-efficient half-door design.

Heavy-duty overall construction for high-volume, constant duty operation.

*Electric condensate evaporator - **no floor drain required!***

Reinforced door hinges with 90 degree hold open feature.

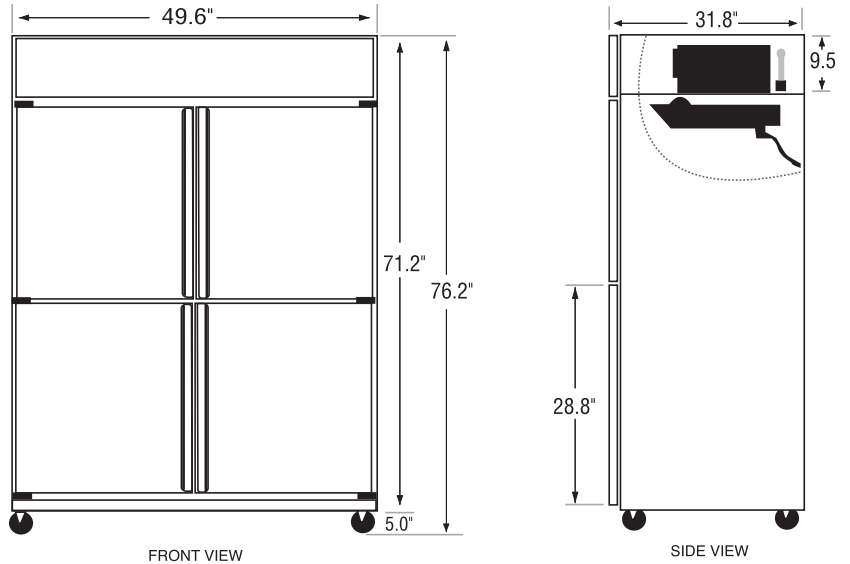
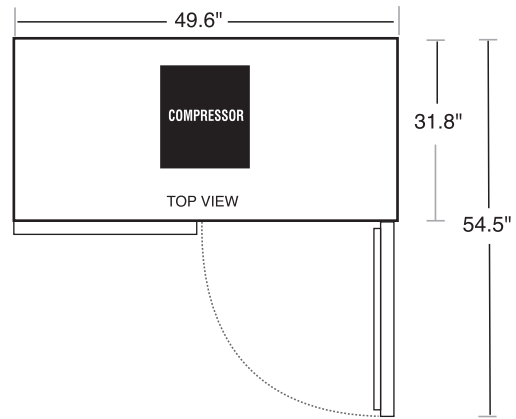

FACTORY OPTIONS

Suffix 1	Suffix 2	Description	Add to List
-4G		Glass doors, light switch	\$2100
-1G		1 glass door, light switch	\$525
	-TR	Top right glass door	
	-TL	Top left glass door	
-2G		2 glass doors, light switch	\$1050
	-T	Top glass doors	
	-L	Left glass doors	
	-R	Right glass doors	



*NEMA 5-15P plug
5-15R receptacle required*

General Information

Cubic Ft.: 40

Shelf Size: 24.75"x22.0"

Half Doors: 4

Unit Weight: 460 lbs.

Exterior: Stainless

Ship Weight: 490 lbs.

Interior: Stainless

Technical Data

Refrigerant: R-134A

Volts: 115

Start Amps: 9.48

#Compressors: 1

Run Amps: 6.32

Cord Length: 82 in.

Horsepower: 1/3