



*Reaching New Heights*

Date Modified 6/2/08

## Four Half Door Refrigerator/Freezer



**JHD-40Q**  
40 cu.ft., 2 section



Patent # **D445, 159S**  
**D445, 160S**  
**D445, 161S**

- Stainless steel interior & exterior standard!***
- Recessed door handles!***
- Exterior digital temperature controls!***
- Convenient low box height design!***
- Unique quarter freezer section!***
- Energy saving half door design!***

**STANDARD FEATURES:**

- Recessed Door Handles
- Self-Contained Top Mounted Refrigeration System
- 2 Vinyl-Coated Wire Shelves per Door
- 5" Casters Included
- Specifically Designed 76.2" High for Easy Mobility and Installation
- Reinforced Door Hinges
- CFC-free R-134a & R-404a Refrigerant
- Evaporative Electric Condensate Pan
- Fully Coved Interior Corners
- Automatic Door Closure with 90° Hold Open Feature
- Door Locks
- 2.5" Thick Foamed-in-place Polyurethane Insulation
- Exterior Digital Temperature Control
- Snap-In Magnetic Door Gaskets
- Assembled in USA

**MATERIALS:**

INTERIOR: Stainless steel interior walls, floor, and ceiling.  
Vinyl-coated wire shelves.  
EXTERIOR: Stainless steel sides and doors



NSF/ANSI Standard 7



ACCREDITED

ISO 17025:2005 Certified

**DIMENSIONAL DATA:**

Model No.	L	D	H	Doors	Cu.Ft.	Shelves	H/P	Volt	Amp.	NEMA	Ship Wt.
JHD-40Q	49.6"	31.8"	76.2"	4	30,10	8	1/4,1/4	115/60/1	10.69	5-20P	540



# Solid Door Refrigerator/Freezer

## JHD-40Q

Description: Four solid half door REF(3dr) FRE(1dr), 40 cu. ft

### Features & Benefits

**Stainless steel interior and exterior for greater durability, construction and appearance.**

**Recessed door handles with plastic door handle gaskets for ease of use.**

Self-contained top mounted refrigeration system and high humidity coated **fin coil** evaporator.

- Holds -10° F to 10° F as freezer
- Holds 30° F to 45° F as refrigerator

Automatic interior lights in refrigerator and freezer sections.

Exterior LED temperature display with digital controls. **Temperature setting is easy, fast and accurate.**

Micro-controller with adjustable temperature variance, automatic defrost intervals, setpoint limits, and parameter locking functions.

8 adjustable vinyl-coated steel wire shelves.

5" casters standard. **Easy mobility and installation.**

**Convenient and energy-efficient half-door design.**

Heavy-duty overall construction for high-volume, constant duty operation.

Electric condensate evaporator - **no floor drain required!**

**Reinforced door hinges with 90 degree hold open feature.**

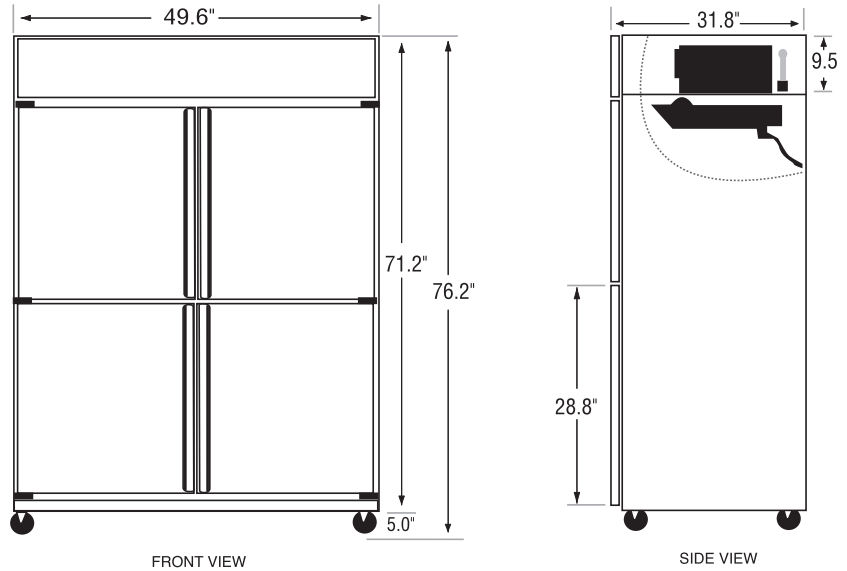
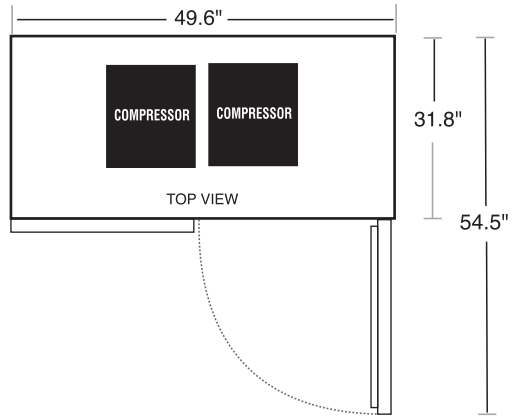

### FACTORY OPTIONS

Suffix 1	Suffix 2	Description	Add to List
-3G (REF only)		Glass doors, light switch	\$1575
-2G (REF only)		2 glass doors, light switch	\$1050
	-T	Top glass doors	
	-L	Left glass doors	
-1G (REF only)		1 glass door, light switch	\$525
	-TL	Top left glass door	
	-TR	Top right glass door	



NEMA 5-20P plug  
5-20R receptacle required

### General Information

**Cubic Ft.:** 30,10

**Shelf Size:** 24.75"x22.0"(x6), 24.75"x20.5"(x2)

**Half Doors:** 4

**Unit Weight:** 495 lbs.

**Exterior:** Stainless

**Ship Weight:** 540 lbs.

**Interior:** Stainless

### Technical Data

**Refrigerant:** R-404a & R-134A

**Volts:** 115

**Start Amps:** 15.4

**#Compressors:** 2

**Run Amps:** 10.69

**Cord Length:** 82 in.

**Horsepower:** 1/4,1/4