



Date Modified 6/2/08

Residential Four Solid Half Door Refrigerator/Freezer



JHD-40H
3/4 refrigerator, 1/4 freezer

Stainless steel interior & exterior standard!
Energy-saving half door design!
Convenient low box height - without sacrificing interior storage space!
Insulated compressor mount - reduces vibration noise!
Energy saving half door design!

STANDARD FEATURES:

- Recessed Door Handles
- Self-Contained Top Mounted Refrigeration System
- 2 Vinyl-Coated Wire Shelves per Door
- 5" Casters Included
- Specifically Designed 76.2" High for Easy Mobility and Installation
- Reinforced Door Hinges
- CFC-free R-134a & R-404a Refrigerant
- Evaporative Electric Condensate Pan
- Fully Covered Interior Corners
- Automatic Door Closure with 90° Hold Open Feature
- Door Locks
- 2.5" Thick Foamed-in-place Polyurethane Insulation
- Exterior Digital Temperature Control
- Snap-In Magnetic Door Gaskets
- Assembled in USA

MATERIALS:

INTERIOR: Stainless steel interior for durability and appearance.
Vinyl-coated wire shelves.

EXTERIOR: Stainless steel cabinet and doors.



NSF/ANSI Standard 7



ACCREDITED
ISO 17025:2005 Certified

DIMENSIONAL DATA:

Model No.	L	D	H	Doors	Cu.Ft.	Shelves	H/P	Volt	Amp.	NEMA	Ship Wt.
JHD-40H	49.6"	32.5"	76.2"	4	30,10	8	1/5, 1/5	115/60/1	6.9	5-20P	530



Solid Door Refrigerator/Freezer

JHD-40H

Description: Four solid half door REF(3dr) FRE(1dr), 40 cu. ft

Features & Benefits

Stainless steel interior and exterior for greater durability, construction and appearance.

Recessed door handles with plastic door handle gaskets for ease of use.

Self-contained top mounted refrigeration system and high humidity coated fin coil evaporator.

- Holds -10° F to 10° F as freezer
- Holds 30° F to 45° F as refrigerator

Automatic interior lights in refrigerator and freezer sections.

*Exterior LED temperature display with digital controls. **Temperature setting is easy, fast and accurate.***

Micro-controller with adjustable temperature variance, automatic defrost intervals, setpoint limits, and parameter locking functions.

8 adjustable vinyl-coated steel wire shelves.

*5" casters standard. **Easy mobility and installation.***

Convenient and energy-efficient half-door design.

Heavy-duty overall construction for high-volume, constant duty operation.

*Electric condensate evaporator - **no floor drain required!***

Reinforced door hinges with 90 degree hold open feature.

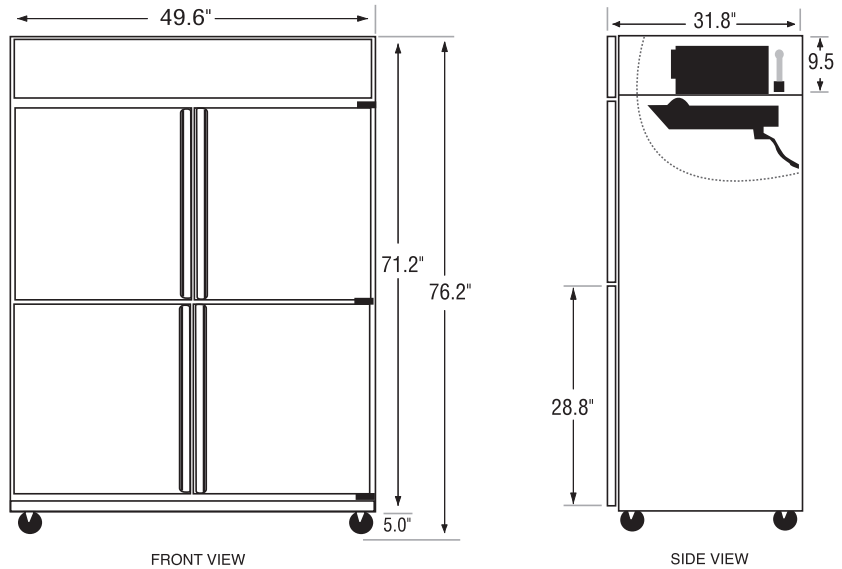
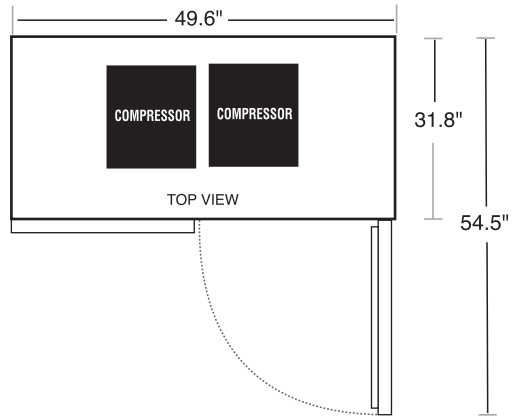

FACTORY OPTIONS

Suffix 1	Suffix 2	Description	Add to List
-3G (REF only)		Glass doors, light switch	\$1575
-2G (REF only)		2 glass doors, light switch	\$1050
	-T	Top glass doors	
	-L	Left glass doors	
-1G (REF only)		1 glass door, light switch	\$525
	-TL	Top left glass door	
	-TR	Top right glass door	



NEMA 5-20P plug
5-20R receptacle required

General Information

Cubic Ft.: 30, 10

Shelf Size: 24.75"x22.0"(x6), 24.75"x20.5"(x2)

Half Doors: 4

Unit Weight: 500 lbs.

Exterior: Stainless

Ship Weight: 530 lbs.

Interior: Stainless

Technical Data

Refrigerant: R-404A & R-134A

Volts: 115

Start Amps: 8.1

#Compressors: 2

Run Amps: 6.7

Cord Length: 96 in.

Horsepower: 1/5, 1/5