



Reaching New Heights

Date Modified 6/2/08

Two Half Door Refrigerator/Freezer



JHD-20DT
20 cu.ft., 1 section



Patent # **D445, 159S**
D445, 160S
D445, 161S

Stainless steel interior & exterior standard!
Recessed door handles!
Exterior digital temperature controls!
Convenient low box height design!

STANDARD FEATURES:

- Recessed Door Handles
- Self-Contained Top Mounted Refrigeration System
- 2 Vinyl-Coated Wire Shelves per Door
- 5" Casters Included
- Specifically Designed 76.2" High for Easy Mobility and Installation
- Reinforced Door Hinges
- CFC-free R-134a & R-404a Refrigerant
- Evaporative Electric Condensate Pan
- Fully Covered Interior Corners
- Automatic Door Closure with 90° Hold Open Feature
- Door Locks
- 2.5" Thick Foamed-in-place Polyurethane Insulation
- Exterior Digital Temperature Control
- Snap-In Magnetic Door Gaskets
- Assembled in USA

MATERIALS:

INTERIOR: Stainless steel interior walls, floor, and ceiling.
Vinyl-coated wire shelves.
EXTERIOR: Stainless steel sides and doors



NSF/ANSI Standard 7



ISO 17025:2005 Certified

DIMENSIONAL DATA:

Model No.	L	D	H	Doors	Cu.Ft.	Shelves	H/P	Volt	Amp.	NEMA	Ship Wt.
JHD-20DT	29.1"	31.8"	76.2"	2	20	4	1/5,1/4	115/60/1	9.6	5-15P	360



Solid Door Freezer / Refrigerator

JHD-20DT

Description: Two solid half door REF (1 dr) FRE(1 dr), 20 cu. ft.

Features & Benefits

Stainless steel interior and exterior for greater durability, construction and appearance.

Recessed door handles with plastic door handle gaskets for ease of use.

Self-contained top mounted refrigeration system and high humidity coated fin coil evaporator.

- Holds -10° F to 10° F as freezer
- Holds 30° F to 45° F as refrigerator

Automatic interior lights.

Exterior LED temperature display with digital controls. Temperature setting is easy, fast and accurate.

Micro-controller with adjustable temperature variance, automatic defrost intervals, setpoint limits, and parameter locking functions.

4 adjustable vinyl-coated steel wire shelves.

5" casters standard. Easy mobility and installation.

Convenient and energy-efficient half-door design.

Heavy-duty overall construction for high-volume, constant duty operation.

Electric condensate evaporator - no floor drain required!

Reinforced door hinges with 90 degree hold open feature.

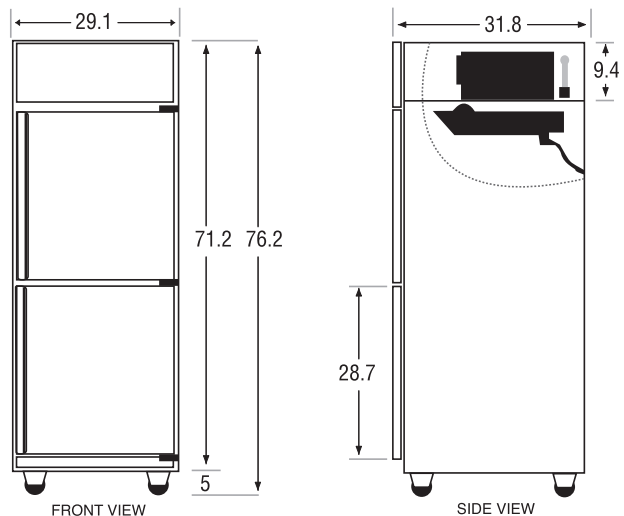
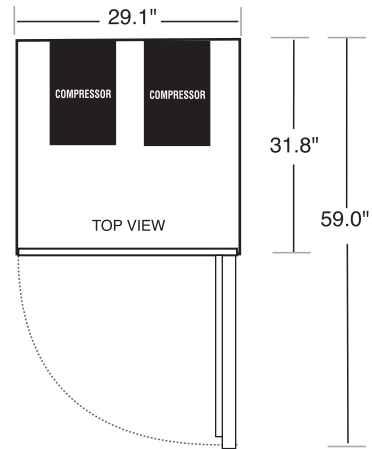

FACTORY OPTIONS

Suffix	Description	Add to List
-LH	Left Hinge	\$200
-FB	Freezer Bottom reconfiguration	\$500
-1G	Top glass door(REF only), light switch	\$525



NEMA 5-15P plug
5-15R receptacle required

General Information

Cubic Ft.: 20

Shelf Size: 24.75"x20.5"

Half Doors: 2

Unit Weight: 335 lbs.

Exterior: Stainless

Ship Weight: 360 lbs.

Interior: Stainless

Technical Data

Refrigerant: R-404A & R-134A

Volts: 115

Start Amps: 14.40

#Compressors: 2

Run Amps: 9.60

Cord Length: 82 in.

Horsepower: 1/5, 1/4