



*Reaching New Heights*

Date Modified 6/2/08

**Two Full Door Freezer**



**JFD-48F**  
48 cu.ft., 2 section

***Stainless steel interior & exterior standard!***  
***Fully-recessed door handles!***  
***Slide shelving system!***  
***Exterior digital temperature controls!***

**STANDARD FEATURES:**

- Fully Recessed Door Handles
- Self-Contained Bottom Mounted Refrigeration System
- 6 Vinyl-Coated Wire Shelves
- 5" Casters Installed
- Door Lock
- Reinforced Door Hinges
- CFC-free R-404a Refrigerant
- Evaporative Hot Gas Condensate Pan
- Fully Coved Interior Corners
- Automatic Door Closure with 90° Hold Open Feature
- Slide Shelving System
- 2.5" Thick Foamed-in-place Polyurethane Insulation
- Exterior Digital Temperature Control
- Snap-In Magnetic Door Gaskets
- Assembled in USA

**MATERIALS:**

INTERIOR: Stainless steel interior walls, floor, and ceiling.  
Vinyl-coated wire shelves.

EXTERIOR: Stainless steel sides and doors.



**DIMENSIONAL DATA:**

Model No.	L	D	H	Cu.Ft.	Shelves	H/P	Volt	Amp.	NEMA	Ship Wt.
JFD-48F	53.5"	32.3"	81.8"	48	6	3/4	115/60/1	9.9	5-20P	490



## Solid Door Freezer JFD-48F

Description: Two solid full door freezer, 48 cu. ft

### Features & Benefits

**Stainless steel interior and exterior for greater durability, construction and appearance.**

Self-contained bottom mounted refrigeration system and high humidity coated **fin coil** evaporator.

- Holds -10° F to 10° F as freezer

Exterior LED temperature display with digital controls. **Temperature setting is easy, fast and accurate.**

Micro-controller with adjustable temperature variance, automatic defrost intervals, setpoint limits, and parameter locking functions.

2.5" thick, foamed-in-place polyurethane high density insulation.

6 adjustable vinyl-coated steel wire shelves. Built-in tray slides to accommodate shelves (standard) or 18"x26" sheet pans (optional).

5" casters standard. **Easy mobility and installation.**

Heavy-duty overall construction for high-volume, constant duty operation.

Self-closing door with 90° hold open feature.

**Door locks** standard.

Door handle gaskets for ease of use.

Hot gas condensate - **no floor drain required!**

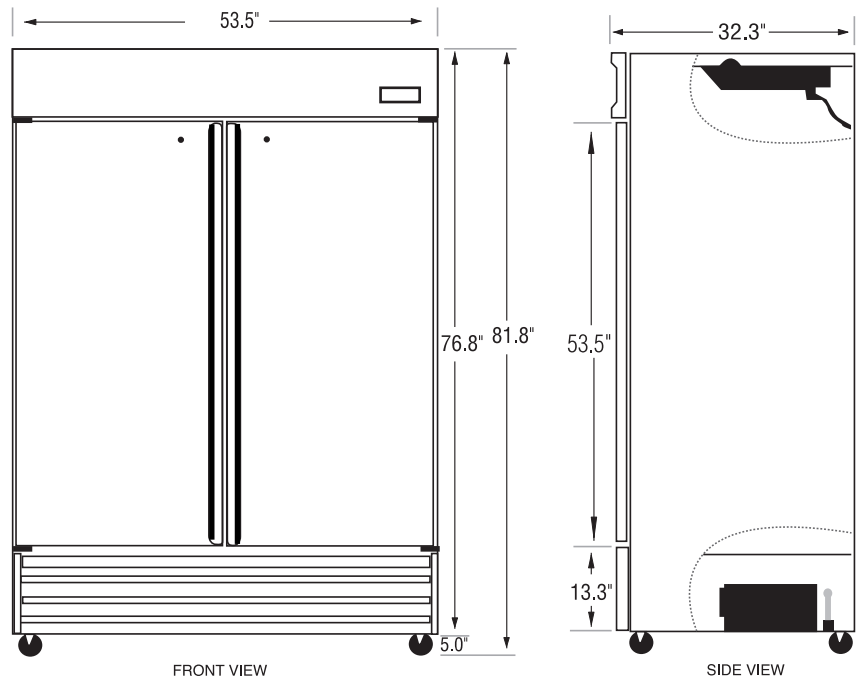
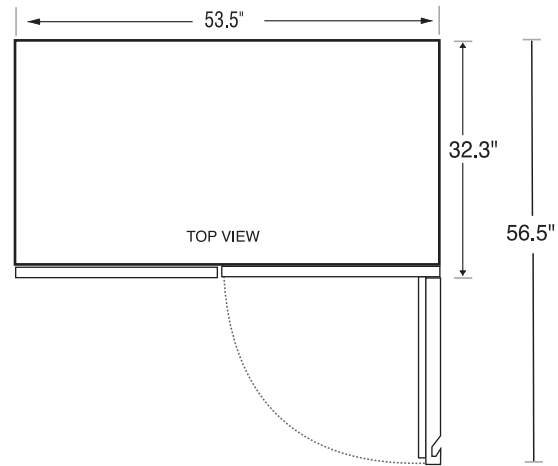

NEMA 5-20P plug  
5-20R receptacle required

### General Information

**Cubic Ft.:** 48

**Shelf Size:** 25.0" x 20.75"

**Doors:** 2

**Unit Weight:** 460 lbs.

**Exterior:** Stainless

**Ship Weight:** 490 lbs.

**Interior:** Stainless

### Technical Data

**Refrigerant:** R-404a

**Volts:** 115

**Start Amps:** 13.8

**#Compressors:** 1

**Run Amps:** 9.9

**Cord Length:** 82 in.

**Horsepower:** 3/4

SPECIFICATIONS SUBJECT TO CHANGE WITHOUT NOTICE