



Reaching New Heights

PROJECT _____

QTY. _____ ITEM NO _____

Date Modified 3/4/09

Three Door Undercounter Refrigerator



JUC-72R
72.0" wide, 18 cu.ft.

Stainless steel interior & exterior standard!
Front breathing!
Stainless steel worktop!

STANDARD FEATURES:

- Front Breathing
- Thermostatic Control
- Stainless Steel Worktop
- CFC-free R-134a Refrigerant
- 3 Vinyl-Coated Wire Shelf
- 5" Casters Included
- Reinforced Door Hinges
- Fully Covered Interior Corners
- Self-Contained Rear Mounted Refrigeration System
- 2.5" Thick Foamed-in-place Polyurethane Insulation
- Fully-Recessed Door Handles
- Automatic Door Closure with 90° Hold Open Feature
- Evaporative Hot Gas Condensate Pan
- Snap-In Magnetic Door Gasket
- Assembled in USA

MATERIALS:

INTERIOR: Stainless steel interior walls, floor, and ceiling.
Vinyl-coated wire shelves.

EXTERIOR: Stainless steel worktop.
Stainless steel sides and doors.



NSF/ANSI Standard 7



C LISTED US

DIMENSIONAL DATA

Model No.	L	D	H	Doors	Cu.Ft.	Shelves	H/P	Volt	Amp.	NEMA	Shipping Wt.
JUC-72R	72.0	29.5	34.8	3	18	3	1/3	115/60/1	9.6	5-15P	345



Undercounter Refrigerator

JUC-72R

Description: Three solid door undercounter refrigerator, 18 cu. ft

Features & Benefits

Stainless steel interior and exterior for greater durability, construction and appearance.

Front breathing for increased efficiency.

Reinforced door hinges.

Self-contained **rear-mounted refrigeration** with high humidity coated fin coil evaporator.

- Holds 32° F to 41° F for refrigerator

2.5" thick, foamed-in-place polyurethane high density insulation.

Three adjustable, vinyl-coated steel wire shelves.

5" casters included- for easy mobility and installation.

Heavy-duty **stainless steel** worktop.

Self-closing doors with 90 degree hold-open feature and fully-recessed handle.

Heavy-duty overall construction for high-volume, constant operation.

FACTORY OPTIONS

Suffix1	Suffix2	Description
-1G		1 glass door
	-L	Left 1 glass door
	-R	Right 1 glass door
	-M	Middle 1 glass door
-2G		2 glass doors
	-L	Left 2 glass doors
	-R	Right 2 glass doors
-3G		3 glass doors

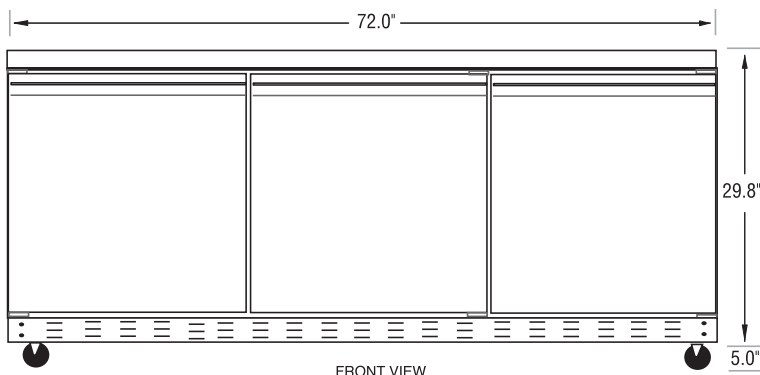
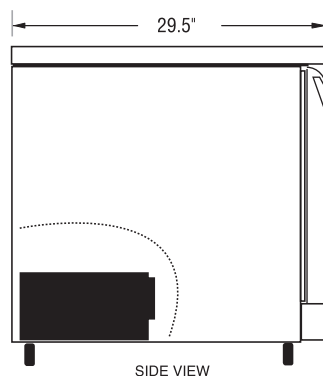
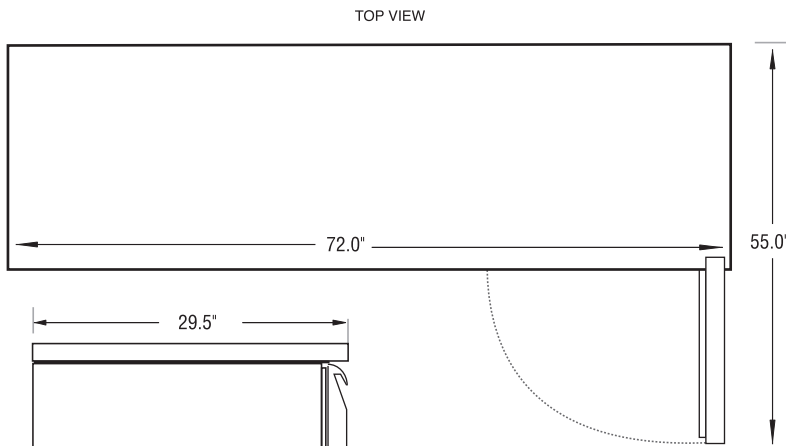

ADA Compliant Unit

(special casters required)

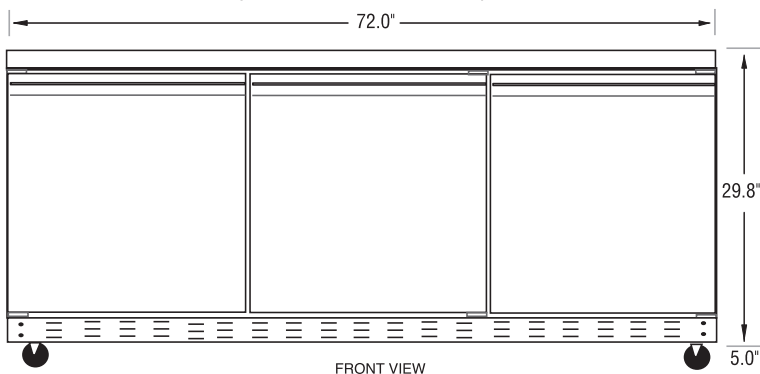

NEMA 5-15P plug
5-15R receptacle required

General Information

Cubic Ft.: 18

Shelf Size: 17.5" x 21.0"

Doors: 3

#Shelves: 3

Exterior: Stainless

Unit Weight: 300 lbs.

Interior: Stainless

Ship Weight: 345 lbs.

Technical Data

Refrigerant: R-134a

Volts: 115

Start Amps: 12.8

#Compressors: 1

Run Amps: 9.6

Cord Length: 82 in.

Horsepower: 1/3