

PROJECT _____

QTY. _____ ITEM NO _____



Reaching New Heights

Date Modified 3/4/09

Three Door Undercounter Freezer



JUC-72F
72.0" wide, 18 cu.ft.

Stainless steel interior & exterior standard!
Front breathing!
Stainless steel worktop!

STANDARD FEATURES:

- Front Breathing
- Thermostatic Control
- Stainless Steel Worktop
- CFC-free R-404a Refrigerant
- 3 Vinyl-Coated Wire Shelf
- 5" Casters Included
- Reinforced Door Hinges
- Fully Coved Interior Corners
- Self-Contained Rear Mounted Refrigeration System
- 2.5" Thick Foamed-in-place Polyurethane Insulation
- Fully-Recessed Door Handles
- Automatic Door Closure with 90° Hold Open Feature
- Evaporative Hot Gas Condensate Pan
- Snap-In Magnetic Door Gasket
- Assembled in USA

MATERIALS:

INTERIOR: Stainless steel interior walls, floor, and ceiling.
Vinyl-coated wire shelves.

EXTERIOR: Stainless steel worktop.
Stainless steel sides and door.



NSF/ANSI Standard 7



DIMENSIONAL DATA

| Model No. | L | D | H | Doors | Cu.Ft. | Shelves | H/P | Volt | Amp. | NEMA | Shipping Wt. |
|-----------|------|------|------|-------|--------|---------|-----|----------|------|-------|--------------|
| JUC-72F | 72.0 | 29.5 | 34.8 | 3 | 18 | 3 | 1/2 | 115/60/1 | 9.6 | 5-15P | 355 |



Undercounter Refrigerator JUC-72F

Description: Three solid door undercounter freezer, 18 cu. ft

Features & Benefits

Stainless steel interior and exterior for greater durability, construction and appearance.

Front breathing for increased efficiency.

Reinforced door hinges.

Self-contained **rear-mounted refrigeration** with high humidity coated fin coil evaporator.

- Holds -10° F to 10° F for refrigerator

2.5" thick, foamed-in-place polyurethane high density insulation.

Three adjustable, vinyl-coated steel wire shelves.

5" casters included- for easy mobility and installation.

Heavy-duty **stainless steel worktop**.

Self-closing doors with 90 degree hold-open feature and fully-recessed handle.

Heavy-duty overall construction for high-volume, constant operation.

Automatic mechanical defrost.



NEMA 5-15P plug
5-15R receptacle required

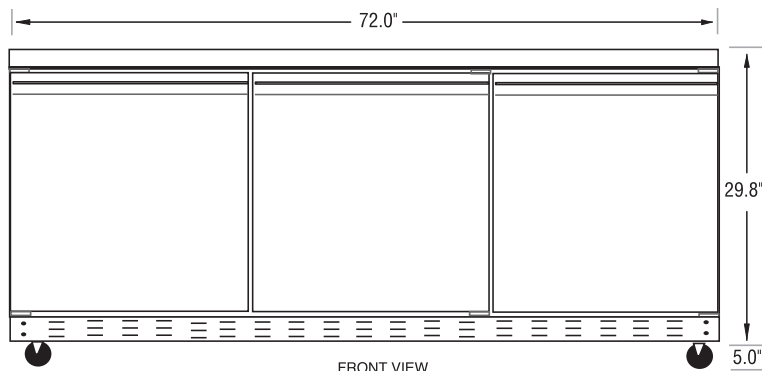
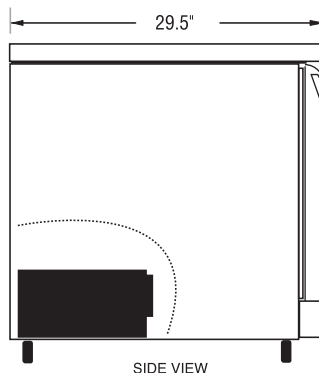
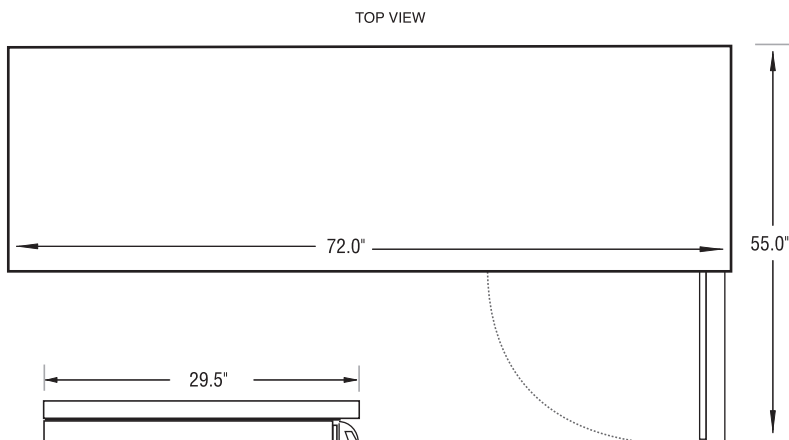

ADA Compliant Unit
(special casters required)

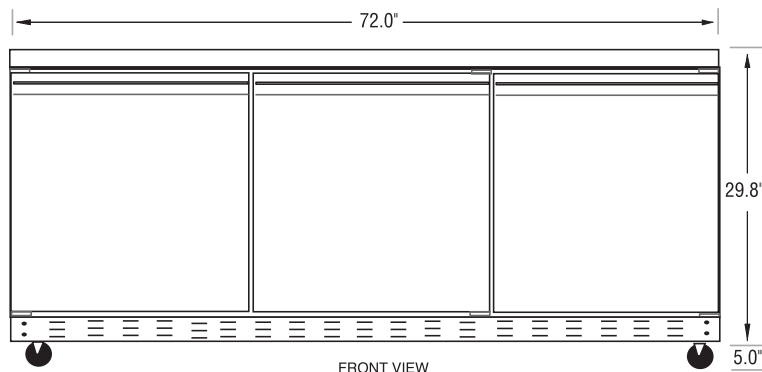

General Information

Cubic Ft.: 18

Shelf Size: 17.5" x 21.0"

Doors: 3

#Shelves: 3

Exterior: Stainless

Unit Weight: 310 lbs.

Interior: Stainless

Ship Weight: 355 lbs.

Technical Data

Refrigerant: R-404a

Volts: 115

Start Amps: 13.2

#Compressors: 1

Run Amps: 9.6

Cord Length: 82 in.

Horsepower: 1/2