



PROJECT _____

QTY. _____ ITEM NO _____

Date Modified 3/4/09

Two Door Deep Undercounter Freezer



JUC-62FD
61.5" wide, 16 cu.ft.



Stainless steel interior & exterior standard!
Exterior digital temperature controls!
Stainless steel worktop!

STANDARD FEATURES:

- Capillary tube
- CFC-free R-404a Refrigerant
- Hot Gas Condensate Evaporator
- Snap-In Magnetic Door Gasket
- Assembled in the USA
- Side-Mounted Condensing System
- Foamed-in-place Polyurethane Insulation
- 2 Vinyl-Coated Wire Shelves per Door
- Slide-out Refrigeration System for quick service
- Exterior Digital Temperature Control
- Fully Covered Interior Corners
- Stainless Steel Worktop
- 5" Casters
- 3' Cord & Plug

MATERIALS:

INTERIOR: Stainless steel interior for durability and appearance.
Vinyl-coated wire shelves.

EXTERIOR: Stainless steel worktop.
Stainless steel cabinet and doors.



NSF/ANSI Standard 7



DIMENSIONAL DATA:

Model No.	L	D	H	Doors	Cu.Ft.	Shelves	H/P	Volt	Amp.	NEMA	Shipping Wt.
JUC-62FD	61.5	33.3	34.8	2	16	4	1/2	115/60/1	6.0	5-15P	350



Undercounter Freezer JUC-62FD

Description: Two solid door deep undercounter freezer, 16 cu. ft

Features & Benefits

Stainless steel interior and exterior for greater durability, construction and appearance.

Self-contained **side-mounted refrigeration** with high humidity coated fin coil evaporator.

- Holds -10° F to 10° F for freezer

Exterior LED temperature display with digital controls. **Temperature setting is easy, fast and accurate.**

Micro-controller with adjustable temperature variance, automatic defrost intervals, setpoint limits, and parameter locking functions.

2.5" thick, foamed-in-place polyurethane high density insulation.

Two adjustable, vinyl-coated steel wire shelves per door.

5" casters standard for easy mobility and installation.

Stainless steel worktop.

Self-closing doors with 90 degree hold-open feature.

Heavy-duty overall construction for high-volume, constant operation.

Hot gas condensate evaporator - no floor drain required!

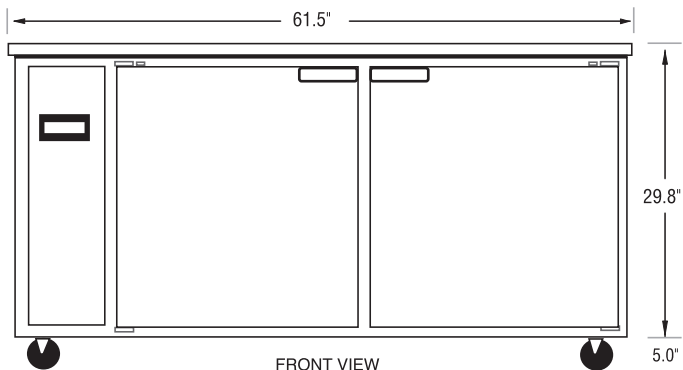
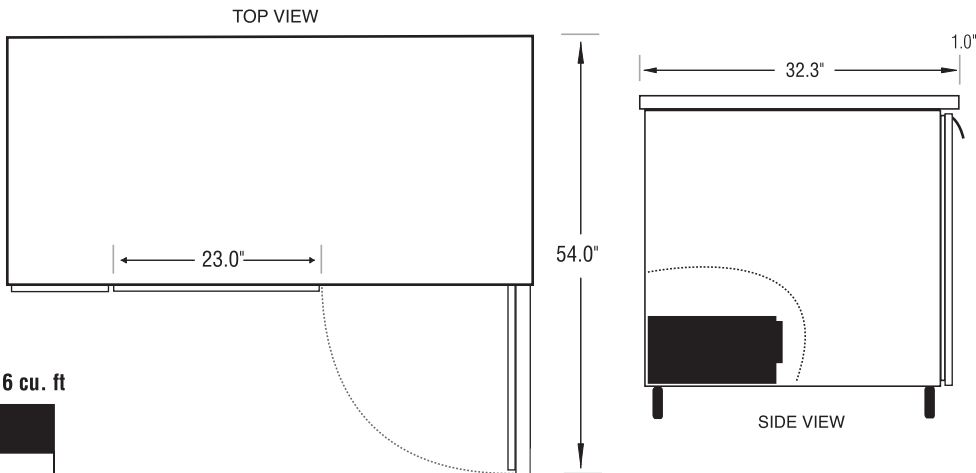

ADA Compliant Unit (special casters required)

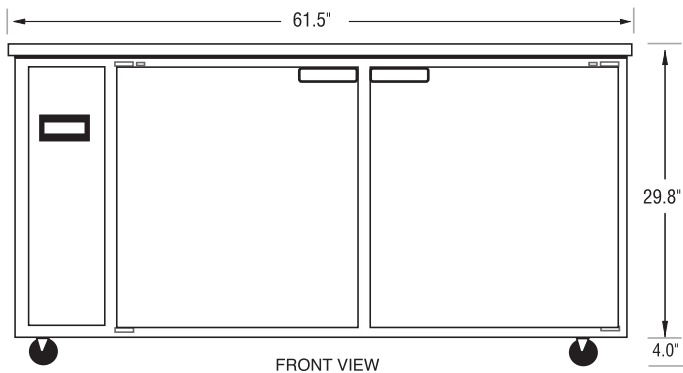

NEMA 5-15P plug
5-15R receptacle required

General Information

Cubic Ft.: 16

Shelf Size: 21.75" x 24.5"

Doors: 2

#Shelves: 4

Exterior: Stainless

Unit Weight: 325 lbs.

Interior: Stainless

Ship Weight: 350 lbs.

Technical Data

Refrigerant: R-404a

Volts: 115

Start Amps: 9.15

#Compressors: 1

Run Amps: 6.0

Cord Length: 82 in.

Horsepower: 1/2