

PROJECT _____

QTY. _____ ITEM NO _____



Reaching New Heights

Date Modified 3/4/09

Two Door Undercounter Refrigerator



JUC-48R
48.0" wide, 12 cu.ft.

Stainless steel interior & exterior standard!
Front breathing!
Stainless steel worktop!

STANDARD FEATURES:

- Front Breathing
- Thermostatic Control
- Stainless Steel Worktop
- CFC-free R-134a Refrigerant
- 2 Vinyl-Coated Wire Shelves
- 5" Casters Included
- Reinforced Door Hinges
- Fully Coved Interior Corners
- Self-Contained Rear Mounted Refrigeration System
- 2.5" Thick Foamed-in-place Polyurethane Insulation
- Fully-Recessed Door Handles
- Automatic Door Closure with 90° Hold Open Feature
- Evaporative Hot Gas Condensate Pan
- Snap-In Magnetic Door Gasket
- Assembled in USA

MATERIALS:

INTERIOR: Stainless steel interior walls, floor, and ceiling.
Vinyl-coated wire shelves.

EXTERIOR: Stainless steel worktop.
Stainless steel sides and doors.



NSF/ANSI Standard 7



DIMENSIONAL DATA

| Model No. | L | D | H | Doors | Cu.Ft. | Shelves | H/P | Volt | Amp. | NEMA | Shipping Wt. |
|-----------|------|------|------|-------|--------|---------|-----|----------|------|-----------|--------------|
| JUC-48R | 48.0 | 29.5 | 34.8 | 2 | 12 | 2 | 1/4 | 115/60/1 | 6.2 | 5-15P 250 | |



Undercounter Refrigerator

JUC-48R

Description: Two solid door undercounter refrigerator, 12 cu. ft

Features & Benefits

Stainless steel interior and exterior for greater durability, construction and appearance.

Front breathing for increased efficiency.

Reinforced door hinges.

Self-contained **rear-mounted refrigeration** with high humidity coated fin coil evaporator.

- Holds 32° F to 41° F for refrigerator

2.5" thick, foamed-in-place polyurethane high density insulation.

Two adjustable, vinyl-coated steel wire shelves.

5" casters included- for easy mobility and installation.

Heavy-duty **stainless steel worktop**.

Self-closing doors with 90 degree hold-open feature and fully-recessed handle.

Heavy-duty overall construction for high-volume, constant operation.



NEMA 5-15P plug
5-15R receptacle required

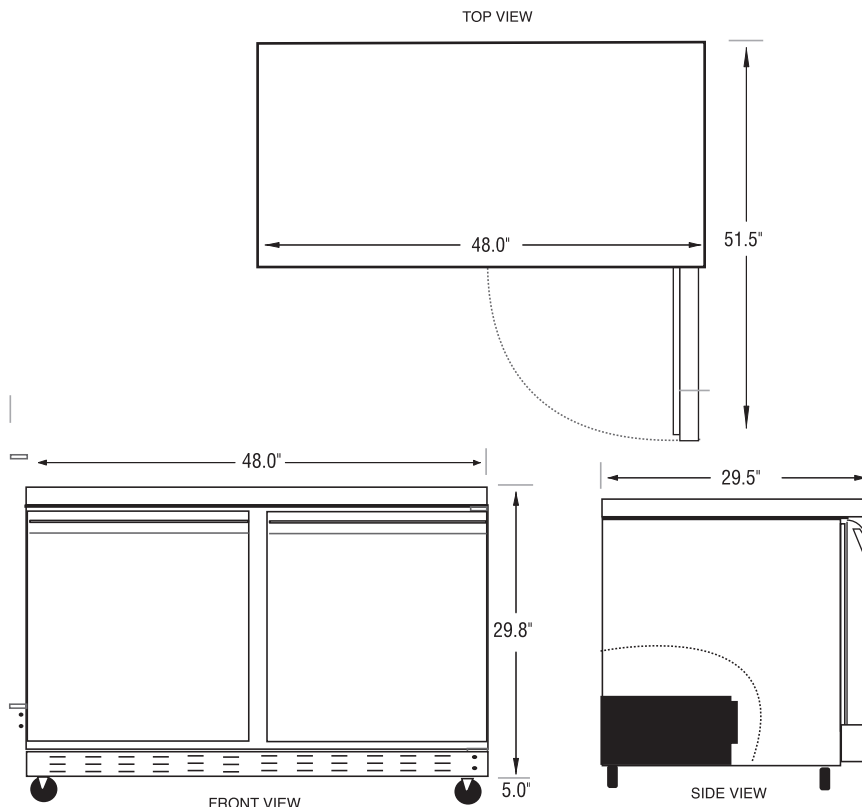

ADA Compliant Unit (special casters required)

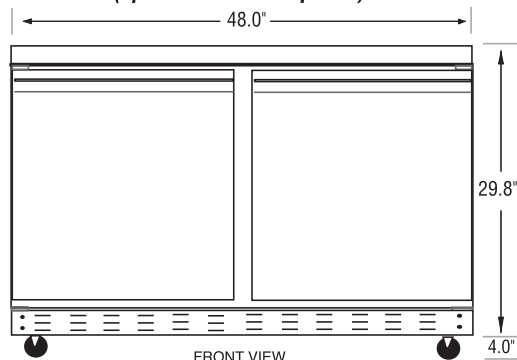

FACTORY OPTIONS

| Suffix1 | Suffix2 | Description |
|---------|---------|--------------------|
| -1G | | 1 glass door |
| | -L | Left 1 glass door |
| | -R | Right 1 glass door |
| -2G | | 2 glass doors |
| -2D | | 2 drawers |
| | -L | Left 2 drawers |
| | -R | Right 2 drawers |
| -4D | | 4 drawers |

General Information

| | | | |
|-----------------------------------|--------------------|------------------------------|------------------------------|
| Cubic Ft.: 12 | Doors: 2 | Exterior: Stainless | Interior: Stainless |
| Shelf Size: 17.5" x 22.75" | #Shelves: 2 | Unit Weight: 225 lbs. | Ship Weight: 250 lbs. |

Technical Data

| | | | |
|----------------------------|------------------------|----------------------------|------------------------|
| Refrigerant: R-134a | Start Amps: 8.3 | Run Amps: 6.2 | Horsepower: 1/4 |
| Volts: 115 | #Compressors: 1 | Cord Length: 82 in. | |