

PROJECT _____

QTY. _____ ITEM NO _____



Reaching New Heights

Date Modified 3/4/09

Two Door Undercounter Freezer



JUC-48F
48.0" wide, 12 cu.ft.

Stainless steel interior & exterior standard!
Front breathing!
Stainless steel worktop!

STANDARD FEATURES:

- Front Breathing
- Thermostatic Control
- Stainless Steel Worktop
- CFC-free R-404a Refrigerant
- 2 Vinyl-Coated Wire Shelves
- 5" Casters Included
- Reinforced Door Hinges
- Fully Coved Interior Corners
- Self-Contained Rear Mounted Refrigeration System
- 2.5" Thick Foamed-in-place Polyurethane Insulation
- Fully-Recessed Door Handles
- Automatic Door Closure with 90° Hold Open Feature
- Evaporative Hot Gas Condensate Pan
- Snap-In Magnetic Door Gasket
- Assembled in USA

MATERIALS:

INTERIOR: Stainless steel interior walls, floor, and ceiling.
Vinyl-coated wire shelves.

EXTERIOR: Stainless steel worktop.
Stainless steel sides and door.



NSF/ANSI Standard 7



DIMENSIONAL DATA

Model No.	L	D	H	Doors	Cu.Ft.	Shelves	H/P	Volt	Amp.	NEMA	Shipping Wt.
JUC-48F	48.0	29.5	34.8	2	12	2	1/2	115/60/1	6.5	5-15P	260



Undercounter Freezer

JUC-48F

Description: Two solid door undercounter freezer, 12 cu. ft

Features & Benefits

Stainless steel interior and exterior for greater durability, construction and appearance.

Front breathing for increased efficiency.

Reinforced door hinges.

Self-contained **rear-mounted refrigeration** with high humidity coated fin coil evaporator.

- Holds -10° F to 10° F for freezer

2.5" thick, foamed-in-place polyurethane high density insulation.

Two adjustable, vinyl-coated steel wire shelves.

5" casters included- for easy mobility and installation.

Heavy-duty **stainless steel worktop**.

Self-closing doors with 90 degree hold-open feature and fully-recessed handle.

Heavy-duty overall construction for high-volume, constant operation.



NEMA 5-15P plug
5-15R receptacle required

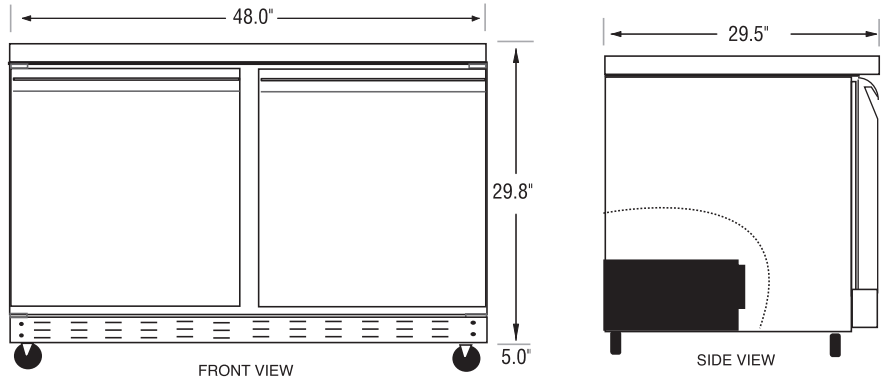
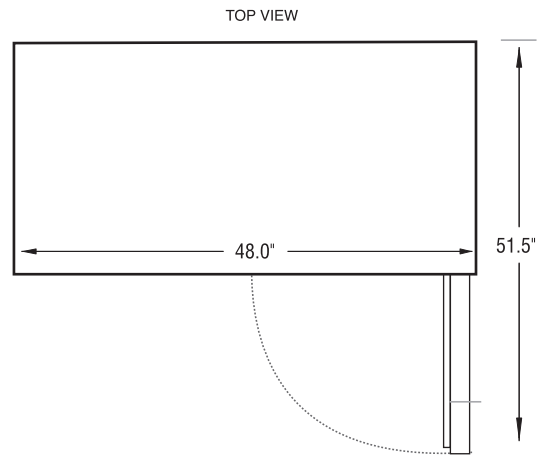

ADA Compliant Unit

(special casters required)

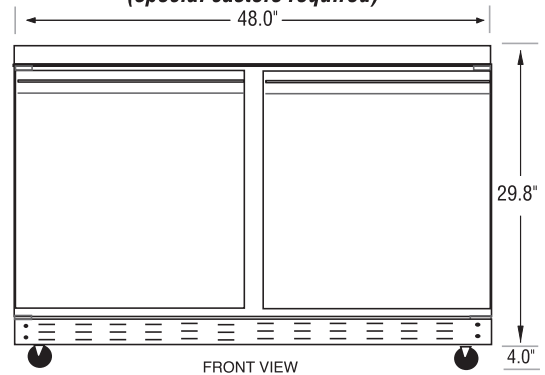

FACTORY OPTIONS

Suffix1	Suffix2	Description
-2D		2 drawers
	-L	Left 2 drawers
	-R	Right 2 drawers
-4D		4 drawers

General Information

Cubic Ft.: 12	Doors: 2	Exterior: Stainless	Interior: Stainless
Shelf Size: 17.5" x 22.75"	#Shelves: 2	Unit Weight: 235 lbs.	Ship Weight: 260 lbs.

Technical Data

Refrigerant: R-404a	Start Amps: 10.8	Run Amps: 6.5	Horsepower: 1/2
Volts: 115	#Compressors: 1	Cord Length: 82 in.	