



CREPE

CONCEPT

ELECTRIC CREPE MACHINES

- Crepe machines designed by people who invented crepes
- Cast iron plates with protective ceramic finish
- Electric crepe machines available with single and double plates
- Equipped with batter spreader
- Thermostatically controlled up to 450°F
- Integral on/off switch

VERSA



400 E/350 E

DIVERSA



400 ED

DISCUS



350FE/400FE

- Compact “space saver” in 120 V
- Equipped with batter spreader
- Thermostatically controlled up to 450°F

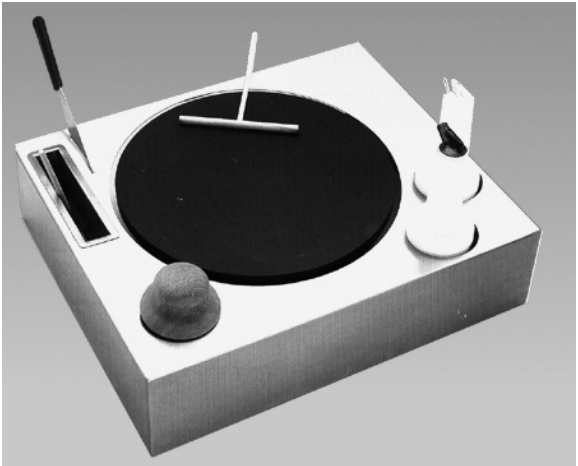

CK-1 Crepe Kit

- Crepe kit adds convenience for storage and cooking
- Includes all stainless steel casing and water vat, batter spreader, spatula, 2 plastic dispensers (for sugar and syrup), oil spreader assembly

CK-2 CREPE KIT

- Free standing kit with same accessories as CK-1 (see reverse side for drawing)



765 WESTMINSTER STREET PROVIDENCE, RI 02903
 TEL: (401)273-3300 FAX: (401)273-3328 E-mail: sales@equipex.com
 www.equipex.com



ELECTRIC CREPE MACHINES



400 ED

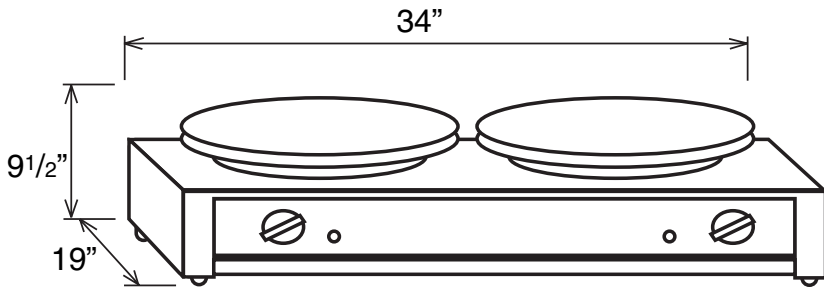

CK-2

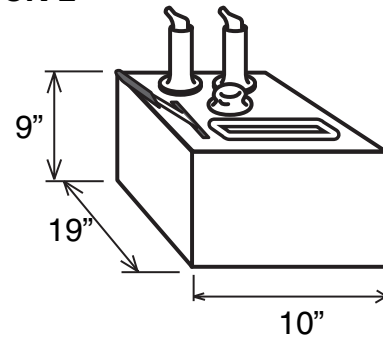

350 FE/400 FE

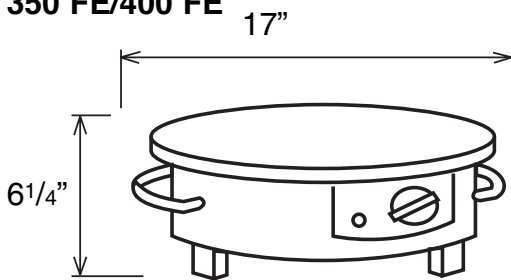

400 E /350 E

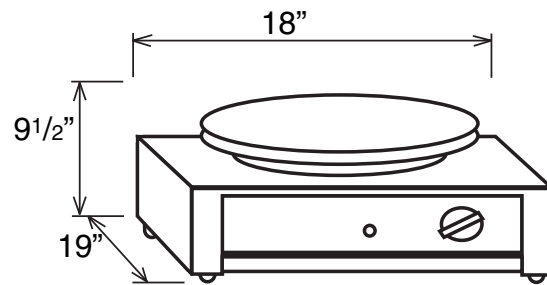

INSTALLATION CLEARANCE : 2" ALL SIDES AND BACK

SPECIFICATIONS

MODEL	ELECTRICAL	DIMENSIONS	WORK SURFACE	SHIPPING WEIGHT	NEMA PLUG
350FE	120V, 1PH 1.65KW, 14 Amps	17" diameter x 6 1/4"H	13 3/4" diameter	40 lbs	5-15 P
400FE	208/240V, 1PH 3.5KW, 13/15 Amps	17" diameter x 6 1/4"H	15 3/4" diameter	42 lbs	6-20 P
350 E	208/240V, 1PH 3.3KW, 12/14 Amps	18"Wx19"Dx9 1/2"H	13 3/4" diameter	45 lbs	6-20 P
400 E	208/240V, 1PH 3.9KW, 15/17 Amps	18"Wx19"Dx9 1/2"H	15 3/4" diameter	45 lbs	6-20 P
400ED	208/240V, 1PH 7.9KW, 29/33 Amps	34"Wx19"Dx9 1/2"H	(2) 15 3/4" diameter	145 lbs	6-50 P
CK-1		24"Wx20"Dx6"H		12 lbs	
CK-2		10"Wx19"Dx9"H		12 lbs	

WARRANTY: Limited one year parts and labor



765 WESTMINSTER STREET PROVIDENCE, RI 02903
 TEL: (401)273-3300 FAX: (401)273-3328 E-mail: sales@equipex.com
 www.equipex.com