





# **MOFFAT® A25CW** Stainless Steel Stand

-  Designed to support the Turbofan E25, E25B, E31, E32 and G32
-  Constructed in stainless steel
-  Casters standard
-  Rack supports
-  Robust



A25CW



Order Toll Free 1800 551 8795

## **A25CW**

Unit shall be a Moffat Turbofan stainless steel stand. The stand shall be constructed from stainless steel tube with casters, 2 swivel and 2 brake. It shall be fitted with 6 sets of tray runners suitable for up to 12 half size sheet pans or 6 full size sheet pans. The stand shall be fully compatible with, and support, Turbofan models E25, E25B, E31, E32, and G32.

# MOFFAT® A25CW

## Stainless Steel Stand

### CONSTRUCTION

Stainless steel frame and rack supports  
Strong, robust and functional  
Casters  
Supplied ckd for assembly on site

### CLEANING AND SERVICING

Easy clean surfaces

### SPECIFICATIONS

#### Nett Weight

40lbs (18kg)

#### Packing Data

42lbs (19kg)

3.2ft<sup>3</sup> (0.09m<sup>3</sup>)

Width 28<sup>3</sup>/<sub>8</sub>" (720mm)

Height 35<sup>1</sup>/<sub>2</sub>" (900mm)

Depth 5<sup>3</sup>/<sub>4</sub>" (145mm)

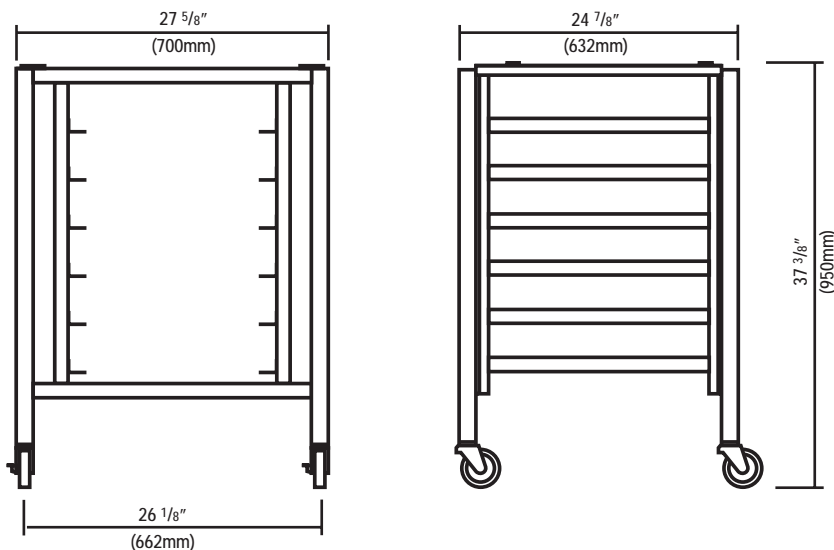

MOFFAT®

www.moffat.com

#### U.S.A

**Moffat Inc**  
3765 Champion Boulevard  
Winston-Salem  
North Carolina 27105  
Call Free 1800 551 8795  
Ph 336-661 0257  
Fax 336-661 9546  
Email sales@moffat.com  
www.moffat.com

#### Canada

**Serve Canada**  
22 Ashwarren Road  
Downview  
Ontario, M3J 1Z5  
Ph 416-631 0601  
Fax 416-631 0315  
Email info@servecanada.com

#### Australia

**Moffat Pty Limited**  
740 Springvale Rd  
Mulgrave  
Victoria 3170  
Australia  
Ph 03-9518 3888  
Fax 03-9518 3833  
Email vsales@moffat.com.au  
www.moffat.com.au

#### New Zealand

**Moffat Limited**  
16 Osborne St  
PO Box 10-001  
Christchurch  
New Zealand  
Ph 03-389 1007  
Fax 03-389 1276  
Email sales@moffat.co.nz  
www.moffat.co.nz

#### United Kingdom

**Blue Seal Limited**  
Units 6-7 Mount St  
Business Park  
Birmingham B7 5QU  
England  
Ph 0121-327 5575  
Fax 0121-327 9711  
Email sales@blue-seal.co.uk  
www.blue-seal.co.uk



#### ISO 9001

All Turbofan products are designed and manufactured by Moffat Ltd using the internationally recognised ISO 9001 quality management system, covering design, manufacture and final inspection, ensuring consistent high quality at all times.