

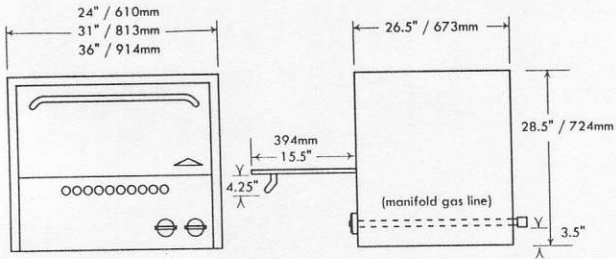

America's Oldest Stove Company  
(Est. 1838)

JOB \_\_\_\_\_ ITEM # \_\_\_\_\_

# PIZZA OVENS



Model PO19 - 230 lbs. / 105 Kgs.  
Model PO26 - 270 lbs. / 123 Kgs.  
Model PO31 - 300 lbs. / 136 Kgs.

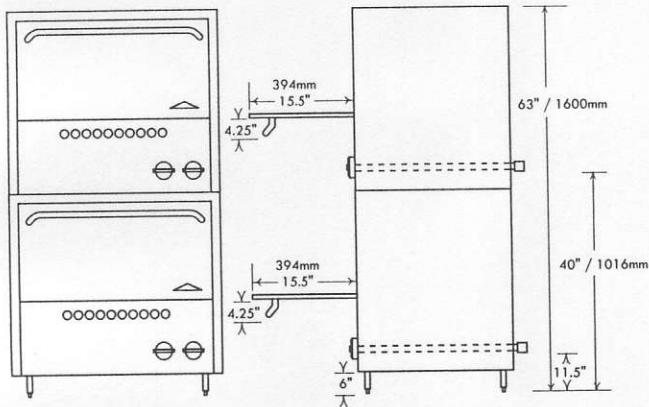

Model 2PO19 - 480 lbs. / 218 Kgs.  
Model 2PO26 - 570 lbs. / 259 Kgs.  
Model 2PO31 - 630 lbs. / 286 Kgs.

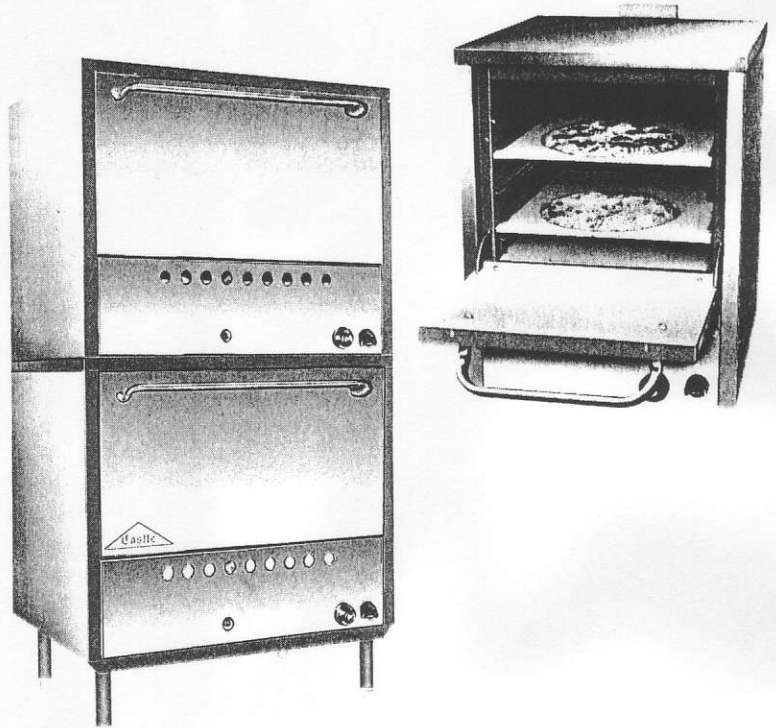

## Standard Features & Benefits

**CONSTRUCTION:** Easy cleaning, corrosion resistant stainless steel finish, welded with angle iron and aluminized inner framing. Double wall construction with heavy insulation for cooler operation. Installation clearances for non-combustible surfaces are 6" on sides and 6" in the rear, combustible surface clearances are 6" and 6".

**OVENS:** All ovens measure 20.5" deep by 14" high. Large oven measures 31.5" wide, for the best baking characteristics and results. Medium oven measures 26.5" wide and small oven measures 19.5" wide. Heavy insulation for fuel efficiency, porcelain and aluminized linings for easy cleaning.

**HEARTH DECKS:** Hearth decks hold heat for superior pizza crust and bread browning. Bake directly on the deck with corn meal, in pans or on screens. 2 hearth decks per oven, 3 positions with 2.5" between rack positions. Decks are interchangeable with wire racks.

**BURNERS:** Long life, cast iron "H" pattern burner is combined with a special "V" shaped baffle directing heat for excellent air circulation. Large and medium ovens feature 30,000 BTU, small ovens feature 25,000 BTU burners.

**CONTROLS:** Includes 650° thermostat, 100% safety shut off, automatic standing pilot and brass burner valves. Pressure regulators are set at the factory for the gas specified. Optimal pressures are 4" WC for natural gas and 10" WC for propane. Manifold size is 3/4" NPT. All controls are tested and confirmed in good working order. Calibration and adjustments are the responsibility of the installer.

**ACCESSORIES:** Gas hoses, flue adapters, draft diverters, carrying handles, knob protectors, matching stands and casters are listed in the price list.

**VERSATILITY:** Castle pizza ovens are stackable in the field or from the factory. Factory ordered stacking ovens come with a 6" high leg base. Leg base is required when stacking in the field.